

## FEATURES

- Measures force & torque simultaneously
- Up to 6 components load cell
- Multiple and custom designs available
- Integrated amplifier optional
- Minimal Cross Effects

## APPLICATIONS

- Mechanical linkage
- Structure testing
- Crash testing
- Automotive testing
- Industrial test benches

## FN7325

### Multi-axial Load Cell

#### SPECIFICATIONS

- **6-Components Load Cell**
- **Force range from 5 kN to 250 kN (1 klbf to 50 klbf)**
- **Measures force in three directions X, Y, Z**
- **Measures torque in three directions Mx, My, Mz**
- **Minimal Cross Effects**

The multi-axial **FN7325** measures force from 0-5 kN to 0-250 kN along three axes as well as the corresponding torque from 0-200 Nm to 0-7000 Nm. The **FN7325** is simple to use and install and in many diverse applications circumvents the necessity of employing multiple single-axes units.

The **FN7325** is a multi-axial sensors based on strain gages technology assembled in Wheatstone full bridges. Each sensor is able to measure up to 6 channels  $F_x$ ,  $F_y$ ,  $F_z$ ,  $M_x$ ,  $M_y$  &  $M_z$  which can be selected by customer, as example **FN7325-M6-ZLM** corresponds to a 3 channels ( $F_z$ ,  $M_x$  &  $M_y$ ) with a M6 sensor design.

Multiple designs and options can be adapted to this sensor such as integrated amplifier (**A1** or **A2**) or separated connectors or cable outputs. Its interfaces can also be modified to fit customer's specifications.

With many years of experience as a designer and manufacturer of sensors, TE CONNECTIVITY often works with customers to design or customize sensors for specific uses and testing environments.

On request, Instruction documents can be provided to ease the selection and use of our sensors and provide helpful tips.

**STANDARD RANGES (FS)**

Model	FN7325-M6	FN7325-M8	FN7325-M10	FN7325-M12	FN7325-M16
<b>Force X/Y in N [in lbf]</b>	5k [1k]	15k [3k]	30k [6k]	60k [12k]	100k [20k]
<b>Force Z in N [in lbf]</b>	15k [3k]	30k [6k]	50k [10k]	100k [20k]	250k [50k]
<b>Torque X/Y/Z in N.m [in lbf.ft]</b>	200 [145]	600 [440]	1.2k [885]	2.8k [2 065]	7k [5 160]

**PERFORMANCE SPECIFICATIONS (typical values at temperature 23±3°C)**

<b>Parameters</b>	
Operating Temperature Range (OTR)	-20 to 80° C [-4 to 176° F]
Compensated Temperature Range (CTR)	0 to 60° C (32 to 140° F)
Thermal Zero Shift in CTR	<1% F.S. / 50° C [100° F]
Thermal Sensitivity Shift in CTR	< 2% of reading / 50° C [100° F]
<b>Over-Range</b>	
Without Damage	1.2 x F.S.
<b>Accuracy</b>	
Combined non-linearity and hysteresis	±1% F.S.
Cross effects	3% F.S. (5% max.)

**Electrical Characteristics**

Model	FN7325	FN7325-A1	FN7325-A2
Supply Voltage	10 Vdc	10 - 30 Vdc	±15 Vdc (±12 to ±18Vdc)
Sensitivity "FSO" per channel <sup>5</sup>	±10 -15 mV/V	±2V ±0.2V	±5 V ±0.2V
Zero Offset <sup>5</sup>	±5% F.S.	2.5 V ±0.2V	0 V ±0.2V
Insulation under 50Vdc	≥100MΩ		

**Notes**

1. Standard electrical Termination: Connector output with mating plug included in delivery
2. Wiring schematic depends on the sensor and number of channels
3. Materials: Body in stainless steel cover in aluminium alloy
4. Protection index: IP50
5. Other signal output on request
6. CE conformance according to EN 61010-1, EN 50081-1, EN 50082-1

**DIMENSIONS** (IN METRIC AND IMPERIAL)

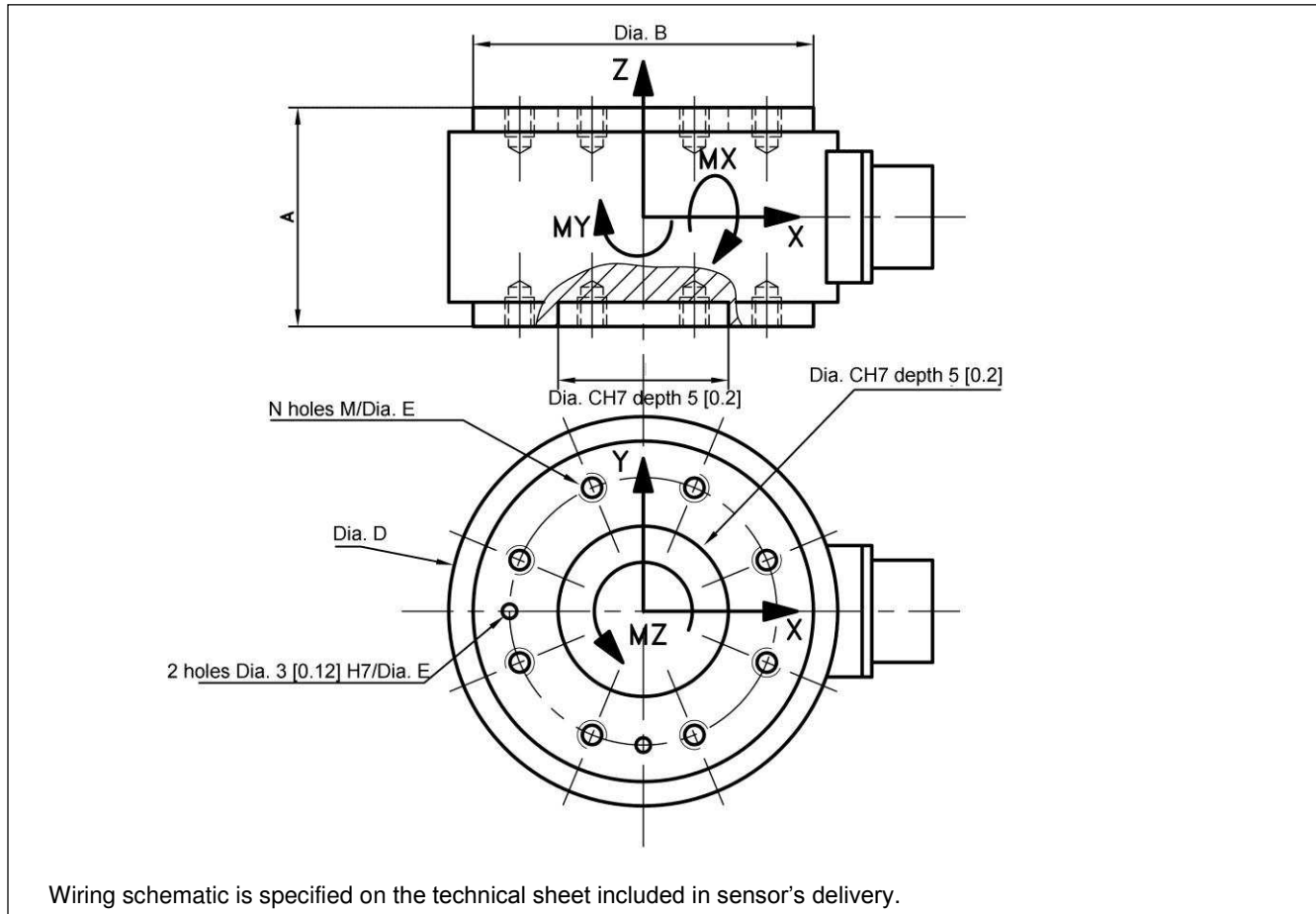

Wiring schematic is specified on the technical sheet included in sensor's delivery.

**Dimensions in mm [inch]**

Model	FN7325-M6	FN7325-M8	FN7325-M10	FN7325-M12	FN7325-M16
Force X/Y in N [in lbf]	5k [1k]	15k [3k]	30k [6k]	60k [12k]	100k [20k]
Force Z in N [in lbf]	15k [3k]	30k [6k]	50k [10k]	100k [20k]	250k [50k]
Torque X/Y/Z in N.m [in lbf.ft]	200 [145]	600 [440]	1.2k [885]	2.8k [2 065]	7k [5 160]
A	50 [1.97]	55 [2.17]	65 [2.56]	75 [2.95]	90 [3.54]
B	70 [2.76]	88 [3.46]	114 [4.49]	148 [5.83]	190 [7.48]
C	35 [1.38]	40 [1.57]	50 [1.97]	65 [2.56]	90 [3.54]
D	80 [3.15]	98 [3.86]	124 [4.88]	158 [6.22]	200 [7.87]
N	8 x M6/Ø55 [2.17]	8 x M8/ Ø70 [2.76]	8 x M10/Ø95 [3.74]	12 x M12/Ø125 [4.92]	12 x M16/Ø150 [5.91]

## FN7325

Multiaxial Load Cell

### OPTIONS

<b>A1</b> : Amplified Tension output with unipolar power supply
<b>A2</b> : Amplified Tension output with bipolar power supply
Cable Gland Terminations with 2 m [6.5 ft] cable

### ORDERING INFO

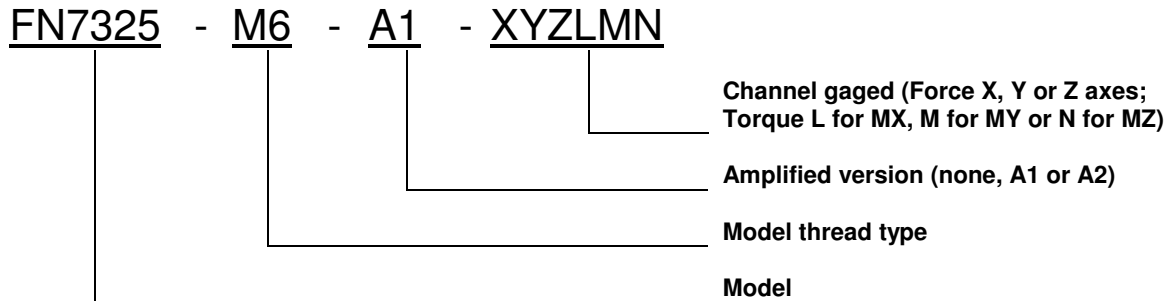

### SUPPLIED ACCESSOIRES (CONNECTOR VERSION)

<b>EFMX-12M</b> : 12CTS mating plug Jaeger 530-502-006 with clamp 630-135-006 up to 3 axes XYZ or with A1 option
<b>EFMX-27HD</b> : 27CTS mating plug Jaeger 762-227-006 with clamp 769-227-006 above 3 axes XYZLMN or with A2 option

#### NORTH AMERICA

Measurement Specialties, Inc.,  
a TE Connectivity Company  
Vibration Design Center  
32 Journey - Suite 150  
Aliso Viejo, CA 92656  
United States USA  
Tel: 1-949-716-0877  
Fax: 1-949-916-5677  
t&m@meas-spec.com

#### EUROPE

Measurement Specialties (Europe), Ltd.,  
a TE Connectivity Company  
26 Rue des Dames  
78340 Les Clayes-Sous-Bois, France  
Tel: +33 (0) 130 79 33 00  
Fax: +33 (0) 134 81 03 59  
cs.lcsb@meas-spec.com

#### ASIA

Measurement Specialties (China), Ltd.,  
a TE Connectivity Company  
No. 26 Langshan Road  
Shenzhen High-Tech Park (North)  
Nanshan District, Shenzhen 518057  
China  
Phone: +86-755-33305088  
Fax: +86-755-33305099  
pfg.cs.asia@meas-spec.com

#### [TE.com/sensorsolutions](http://TE.com/sensorsolutions)

Measurement Specialties, Inc., a TE Connectivity company.

Measurement Specialties, TE Connectivity, TE Connectivity (logo) and EVERY CONNECTION COUNTS are trademarks. All other logos, products and/or company names referred to herein might be trademarks of their respective owners.

The information given herein, including drawings, illustrations and schematics which are intended for illustration purposes only, is believed to be reliable. However, TE Connectivity makes no warranties as to its accuracy or completeness and disclaims any liability in connection with its use. TE Connectivity's obligations shall only be as set forth in TE Connectivity's Standard Terms and Conditions of Sale for this product and in no case will TE Connectivity be liable for any incidental, indirect or consequential damages arising out of the sale, resale, use or misuse of the product. Users of TE Connectivity products should make their own evaluation to determine the suitability of each such product for the specific application.

© 2015 TE Connectivity Ltd. family of companies All Rights Reserved.