

Flowrox™ heavy duty pinch valves

Open Valve (PV)
Enclosed Valve (PVE)
Enclosed/Sealed Valve (PVE/S)

Installation, maintenance and
operating instructions



These instructions must be read carefully and understood prior to the installation, use, and servicing of this product.

DISCLAIMER

ALL INTELLECTUAL PROPERTY RIGHTS TO THIS MANUAL ("MANUAL") BELONG TO VALMET CORPORATION ("VALMET") WHICH REMAINS THE SOLE OWNER OF THESE RIGHTS. OWNERSHIP OF THESE RIGHTS ARE NOT TRANSFERRED FROM VALMET TO ANYONE IN CONNECTION WITH THIS MANUAL. THIS MANUAL IS INTENDED TO BE USED ONLY BY VALMET'S CUSTOMER AND EXCLUSIVELY FOR THE PURPOSES OF THE AGREEMENT UNDER WHICH THIS MANUAL IS DELIVERED TO VALMET'S CUSTOMER. WITHOUT THE PRIOR WRITTEN EXPLICIT CONSENT FROM VALMET, NO PART OF THIS MANUAL SHALL BE USED, REPRODUCED, COPIED, TRANSLATED, CONVERTED, ADAPTED, STORED IN A RETRIEVAL SYSTEM, COMMUNICATED OR TRANSMITTED BY ANY MEANS, OR FOR ANY COMMERCIAL OR OTHER PURPOSES, INCLUDING, BUT NOT LIMITED TO, SALE, RESALE, LICENS, RENT OR LEASE.

THIS MANUAL PROVIDES INSTRUCTIONS TO CARRY OUT CERTAIN ACTIVITIES AND IS DESIGNED AND MEANT TO GUIDE AND ASSIST PROFESSIONAL AND PROPERLY TRAINED EXPERTS IN PERFORMING THEIR FUNCTIONS. EVERYONE MUST BECOME FAMILIAR WITH ALL INSTRUCTIONS IN THIS MANUAL BEFORE ANY INSTALLATION, USE, MAINTENANCE, REPAIR OR ANY OTHER ACTIONS OF THE RESPECTIVE GOODS AND/OR SERVICES WHICH THIS MANUAL APPLIES TO. ALL INSTRUCTIONS MUST BE FOLLOWED CAREFULLY. HOWEVER, OBSERVANCE OF ANY PART OF THE INSTRUCTIONS PRESENTED IN THIS MANUAL MAY BE OMITTED IN EVENT WHEN IT IS REQUIRED OR ALLOWED BY LAW

VALMET HAS TAKEN EVERY CARE IN THE PREPARATION OF THE CONTENT OF THIS MANUAL, BUT DOES NOT MAKE ANY REPRESENTATIONS, WARRANTIES OR GUARANTEES OR, EXPRESS OR IMPLIED, AS TO THE ACCURACY OR COMPLETENESS OF THIS MANUAL. ALL USERS MUST UNDERSTAND AND BE AWARE THAT UPDATES AND AMENDMENTS WILL BE MADE FROM TIME TO TIME TO THIS MANUAL. ALL USERS ARE OBLIGATED TO FIND OUT AND DETERMINE WHETHER THERE HAVE BEEN ANY APPLICABLE UPDATES OR AMENDMENTS TO THIS MANUAL. NEITHER VALMET NOR ANY OF ITS DIRECTORS, OFFICERS, EMPLOYEES, SUBCONTRACTORS, SUB-SUPPLIERS, REPRESENTATIVES OR AGENTS SHALL BE LIABLE IN CONTRACT, TORT OR IN ANY OTHER MANNER WHATSOEVER TO ANY PERSON FOR ANY LOSS, DAMAGE, INJURY, DEATH, LIABILITY, COST OR EXPENSE OF ANY NATURE, INCLUDING WITHOUT LIMITATION INDIRECT, INCIDENTAL, SPECIAL, CONSEQUENTIAL, PUNITIVE OR DIRECT DAMAGES AND/OR LOSSES ARISING OUT OF OR IN CONNECTION WITH THE CREATION, DELIVERY, POSSESSION AND/OR USE OF THIS MANUAL. HOWEVER, NOTHING IN THIS PARAGRAPH IS DEEMED TO EXCLUDE OR RESTRICT ANY LIABILITY WHICH CANNOT BY MANDATORY LAW BE EXCLUDED.

FLOWROX IS EITHER REGISTERED TRADEMARK OR TRADEMARK OF VALMET OR ITS SUBSIDIARIES OR AFFILIATES IN THE UNITED STATES AND/OR IN OTHER COUNTRIES. ALL OTHER TRADEMARKS, LOGOS, BRANDS AND MARKS DISPLAYED IN THIS MANUAL ARE PROPERTY OF THE RESPECTIVE OWNERS UNLESS STATED OTHERWISE.

Copyright © 2014-2022 Valmet corporation. All rights reserved.

Table of Contents

1	EU DECLARATION OF CONFORMITY	4	APPENDIX A: DIMENSIONS	20
2	GENERAL	5	APPENDIX B: HOW TO ORDER	22
2.1	General safety instructions for PV & PVE valves	5		
3	INTRODUCTION TO DEVICE	6		
3.1	Intended use	6		
3.2	Mechanical structure	6		
3.3	Valve function	11		
4	TRANSPORTATION, STORAGE AND LIFTING	12		
4.1	Receiving	12		
4.2	Storage	12		
5	INSTALLATION	13		
5.1	Open body model (PV)	13		
5.2	Enclosed body model (PVE and PVE/S)	13		
5.3	All models (PV, PVE and PVE/S)	13		
6	OPERATION	15		
6.1	First use	15		
6.2	During operation	15		
7	MAINTENANCE	15		
7.1	Schedule	15		
7.2	Changing the valve sleeve	15		
7.3	Adjusting the valve	17		
7.4	Troubleshooting	19		

READ THESE INSTRUCTIONS FIRST!

These instructions provide information about safe handling and operation of the product.

If you require additional assistance, please contact the manufacturer or manufacturer's representative.

SAVE THESE INSTRUCTIONS!

Addresses and phone numbers are printed on the back cover.

1 EU DECLARATION OF CONFORMITY

This declaration of conformity is issued under the sole responsibility of the manufacturer:

VALMET FLOW CONTROL OY

Marssitie 1

53600 Lappeenranta

Finland

Tel. +358 (0)10 417 5000

Product model/type: Pinch Valve (PV, PVE, PVE/S, PVS)

The object of the declaration described above is in conformity with the relevant Union harmonisation legislation:

Machinery Directive 2006/42/EC: Annex IIB partly completed machinery

ATEX Directive 2014/34/EU: Non-electrical equipment

As the product may be used as parts or components in machinery, we declare that this product must not be put into service until the relevant machinery into which it is to be incorporated has been declared in conformity with the provisions of the Machinery Directive.

Follow the valve installation, operating and maintenance instructions in this manual.

Person authorised to compile the technical file is Technology Manager Jarmo Partanen.

On behalf of Valmet Flow Control Oy

In Lappeenranta, 13th May 2022



Riku Salojärvi







Head of Operations





2 GENERAL



2.1 General safety instructions for PV & PVE valves

In this manual, the following symbols are used to highlight the parts requiring particular attention:

Hazard severity panels.

	 <p>DANGER!</p> <p>DANGER indicates a hazard with a high level of risk which, if not avoided, will result in death or serious injury.</p>
	 <p>WARNING!</p> <p>WARNING indicates a hazard with a medium level of risk which, if not avoided, could result in death or serious injury.</p>
	 <p>CAUTION!</p> <p>CAUTION indicates a hazard with a low level of risk which, if not avoided, could result in minor or moderate injury.</p>

SYMBOL	DESCRIPTION
	Risk to personal safety: Neglecting the safety measures can cause serious personal injury or death.
	Electrical safety: Neglecting the safety measures can cause serious personal injury or death.
	Crushing hazard
	Mandatory action symbol: Obey these instructions to prevent machine malfunctions.

SYMBOL	DESCRIPTION
	Read the operation and maintenance instructions: Read and understand the operation and maintenance instructions before using the product.
	Forbidden action symbol.

3 INTRODUCTION TO DEVICE

3.1 Intended use

Open type PV.

The open body is available in diameters starting from 80mm.

The open body construction is designed for applications with:

- Low pressures
- Low temperatures
- Non-hazardous media

The open body construction is light and simple, which makes it easy to access for service. The open body also tolerates misalignment and vibration.

Enclosed type PVE.

The valve sleeve is covered by the body housing and thus protected from the environmental impacts and sunlight.

- Body construction prevents leakage of flowing media to the environment
- The valve body can be equipped with a gauge indicating pressure changes inside the body

3.2 Mechanical structure

Flowrox valves are made of three main components:

- flanged valve sleeve
- valve body, either open PV or enclosed PVE
- actuator and actuator control components, if applicable

The valve sleeve is the only part of the valve which is in contact with the medium flowing in the pipeline.

All valve bodies are flange ended. The standard flange drillings can be made to meet all standards (e.g. DIN, ANSI, BS, AS, JIS).

The face to face dimensions of Flowrox valves are according to ANSI/ISA 75.10.02:

- 165 mm (6.5 in) for valves DN25....D65 (1 in ... 2.5 in)
- 2 ½ times the nominal diameter for valves DN80 (3 in) and bigger

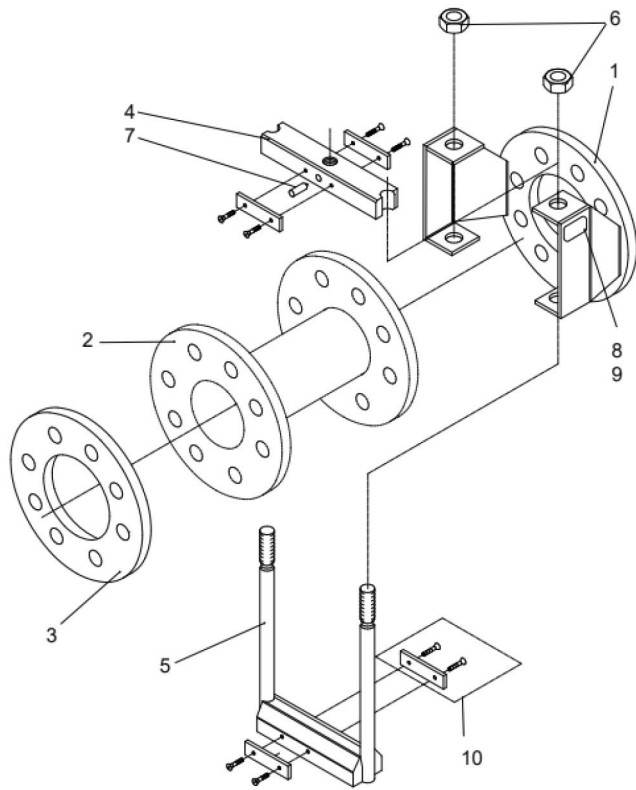

Figure 1. Exploded view of PV valve

Part	Description	Part	Description
1	Valve body	6	Hex nut
2	Sleeve	7	Set screw
3	Flange	8	Tag plate
4	Upper pinch bar	9	Drive screw
5	Lower pinch bar	10	Fixing set

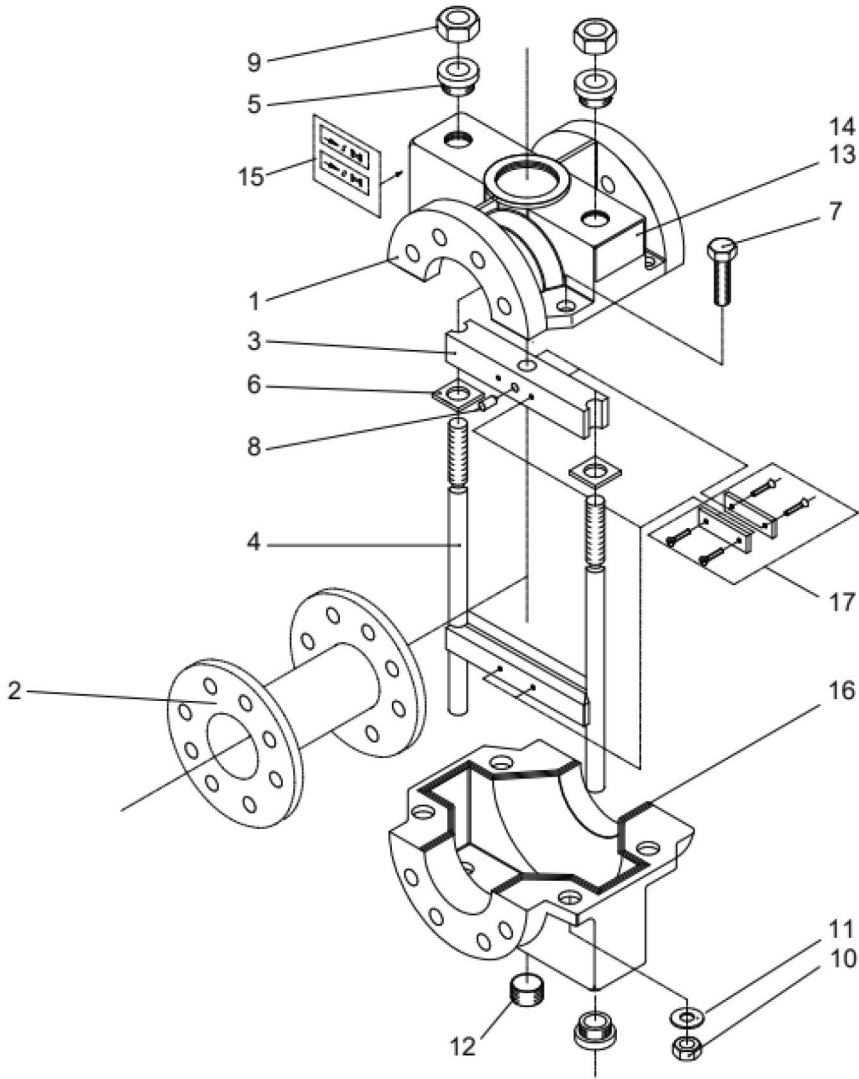

Figure 2. Exploded view of PVE valve

Part	Description	Part	Description
1	Valve body	10	Hex nut
2	Sleeve	11	Washer
3	Upper pinch bar	12	Plug
4	Lower pinch bar	13	Tag plate
5	Bushing	14	Drive screw
6	Guide plate	15	Sticker
7	Hex screw	16	Sealing
8	Set screw	17	Fixing set
9	Hex nut		

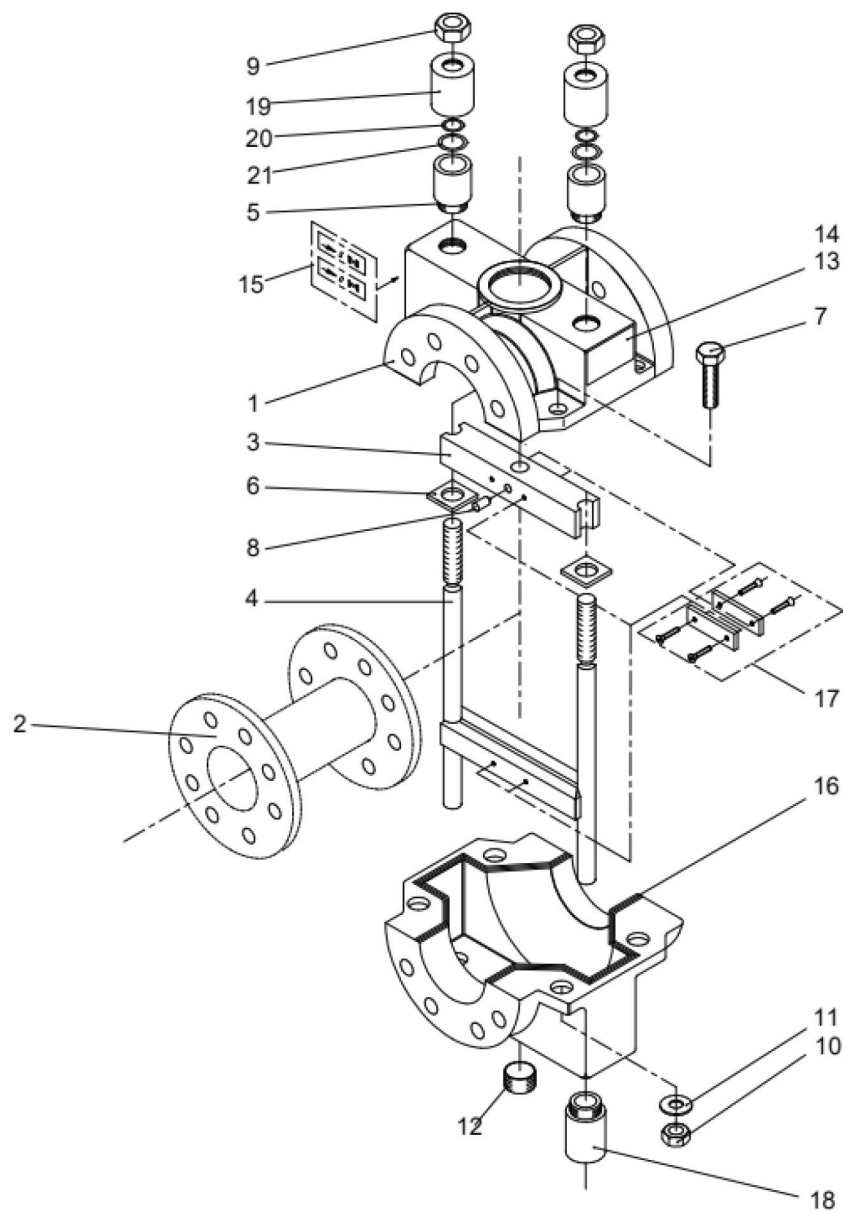

Figure 3. Exploded view of PVE/S valve

Part	Description	Part	Description
1	Valve body	12	Plug
2	Sleeve	13	Tag plate
3	Upper pinch bar	14	Drive screw
4	Lower pinch bar	15	Sticker
5	Bushing	16	Sealing
6	Guide plate	17	Fixing set
7	Hex screw	18	Bushing
8	Set screw	19	Cover bushing
9	Hex nut	20	Sealing
10	Hex nut	21	Sealing
11	Washer		

Open body valve PV

In the open body model the body and the actuator are connected only to one of the end flanges (Figure 4). The construction allows a slight deviation in the pipe angle and the valve can act as a vibration absorber.

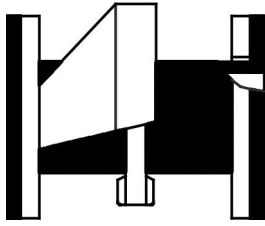

Figure 4.

	CAUTION!
	<p>Harmful substance hazard.</p> <p>In case of a sleeve failure, slight leakage will occur through the bushings.</p> <p>If you open the plug for checking, be careful as the medium may flow out.</p>

	<p>Changing the sleeve at appropriate intervals prevents leakages.</p>
--	--

	<p>Note that in case of a sleeve breakage, the flowing liquid will leak into the environment.</p>
--	---

Enclosed body valve PVE

The body of the enclosed model prevents excessive leakage of flowing media to the environment (Figure 5). The lower part of the body has a plug, which can be opened to check for sleeve failure.

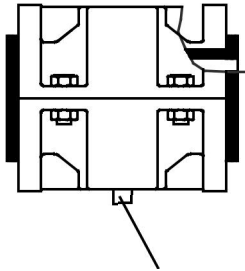

Figure 5. plug

Enclosed/Sealed body valve PVE/S

The PVE/S includes extra stem and body seals to provide a secondary containment of the fluid in the valve and to prevent leakage to the outside environment from the valve body. The lower part of the body has a plug, which can be opened to check for sleeve failure.

Actuators

Manual

Manual gear operated valves are closed by turning clockwise.

Pneumatic

Pneumatic actuators are with a fixed stroke and do not require external controls to position the gate. The pneumatic actuator is designed for a nominal supply of 6 bar. Use correct sized pneumatic hoses to ensure sufficient air flow.

The air must be clean, dry, lubricated and properly filtered. An air quality of minimum requirement to ISO 8573-1:2010 [7:4:4] is recommended. If any component used on the valve has a stricter requirement, the stringent shall prevail.

	CAUTION!
	<p>Noise hazard.</p> <p>Pneumatic actuator noise level can exceed 85 dB and cause an injury.</p>
	<p>Use ear protectors when working near the valve.</p>

Hydraulic

Hydraulic actuators have a minimum supply pressure of 150 bar (2250 psi). The recommended hydraulic fluid is mineral oil. For more information, refer to OEM datasheet.



Electric

Electric actuators have open/close limit switches preset at the factory. A separate instruction from the actuator manufacturer is always included in the shipment.

Consult the manufacturer's instructions on actuator requirements or/and limitations. If actuator is changed or valve needs adjustment, follow the Maintenance instructions.

Make sure that the 3-phase electrical connection is done correctly. If the connection is done wrong, the limit or torque switches will not trigger as designed. This will allow the actuator to move beyond limits and cause damage to the valve.

3.3 Valve function

	 WARNING!
	Crushing and cutting hazard.
	Do not put your hands or fingers between the moving parts when the valve cycles. Do not energize the actuator before the valve is properly attached to the pipeline. Disconnect and de-energize the actuator before installation and maintenance work.

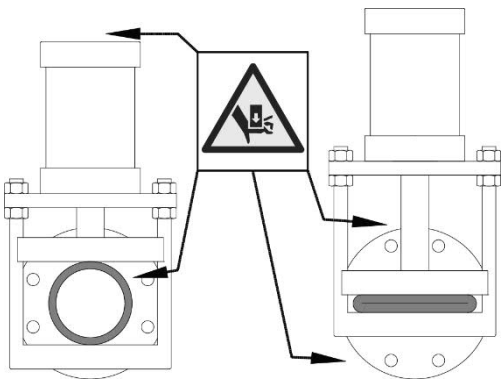
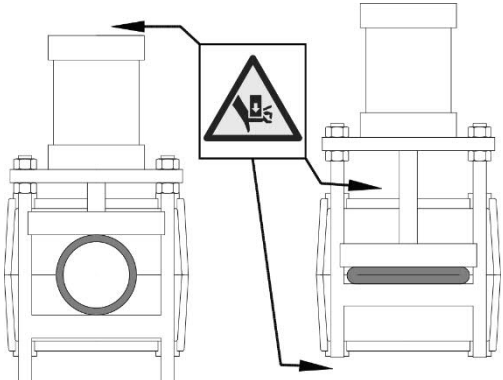
<p>Note the dangerous places (see Figure 6 and Figure 7)!</p> <p>When the pinch valve closes, two pinch bars, moved by the actuator, squeeze the sleeve, closing on the centre line. When the valve is fully closed, the actuator is raised one half of the valve diameter.</p> <p>The actuator raises in all models (PV, PVE and PVE/S) 0.5 x valve nominal diameter (measure X).</p> <p>In the open model the space between the pinch bars, the space between the upper pinch bar and fixing plate of the actuator and the space below the lower pinch bar.</p>	
	<p>Figure 6. PV open model</p>
<p>In the enclosed model the space between the valve body and the fixing plate of the actuator and the ends of the guide bars of lower pinch bar below the valve body.</p>	
	<p>Figure 7. PVE enclosed model</p>

Regarding the actuators, follow the instructions of the manufacturer.

	Note the possible remote control of automatic valves and turn it off before starting maintenance.
---	---

4 TRANSPORTATION, STORAGE AND LIFTING

4.1 Receiving

Check the condition of the valve package on arrival. If it shows signs of transport damage, check the operation of the valve carefully. Normally, a visual inspection of the valve is sufficient. However, if valve has been damaged during transport, contact your nearest Valmet Flow Control Oy sales office immediately.

4.2 Storage

The sleeves must be stored as follows:

- The storing temperature should not exceed +25°C (+77°F), preferably below +15°C (+59°F) but not under +5 °C (+41 °F). Keep the storage temperature as constant as possible.
- Store the sleeves in a dry place. Prevent water from condensing on sleeve surfaces.
- Avoid ultraviolet light. Protect the sleeves against straight sunlight. Use warehouse instead of storing outside.
- Remove all equipment generating ozone from the room where sleeves are stored. Minimize the store room ventilation.
- Store sleeves so that they are free from tension. Sleeves should be stored in vertical position on smooth support. Do not store sleeves one on top of another.
- Keep the sleeves off the chemical effect of solutions, semi-solids, impurities and solvent vapours during storing.
- Try to keep the storing time of sleeves as short as possible. Always use first the material which has been longest in stock.

Lifting

Lift the valves securely from the body (part 1 in Mechanical structure) and use existing lifting eyes when available. When lifting eyes are not available use soft straps to lift valve. When lifting with soft straps, fasten the straps to the valve as shown.

Note the centre of gravity and support the valve to avoid it from turning around. In some models the centre of gravity is located towards the actuator.

Do not attach lifting equipment to the valve bore or actuator as they can get damaged.

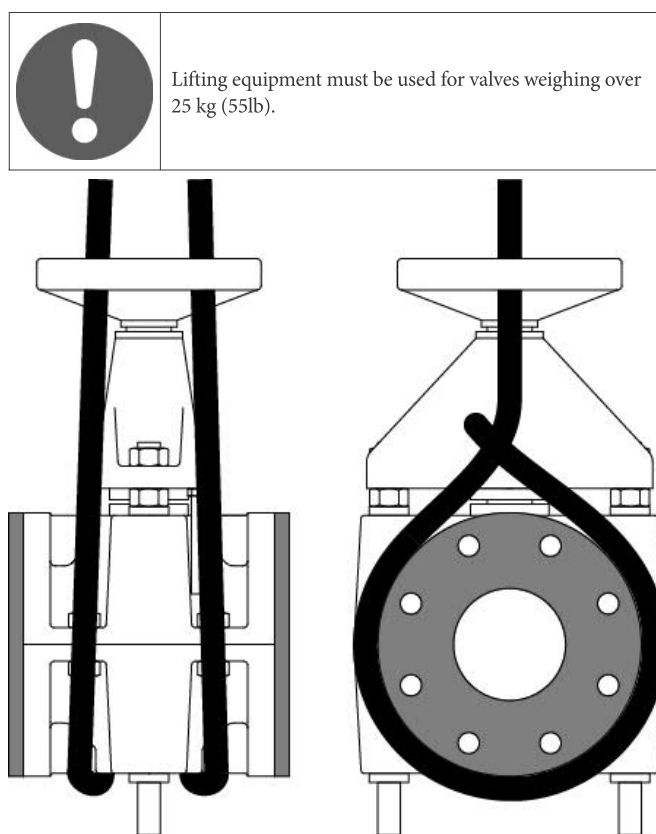

Figure 8. Lifting PVE manual valve

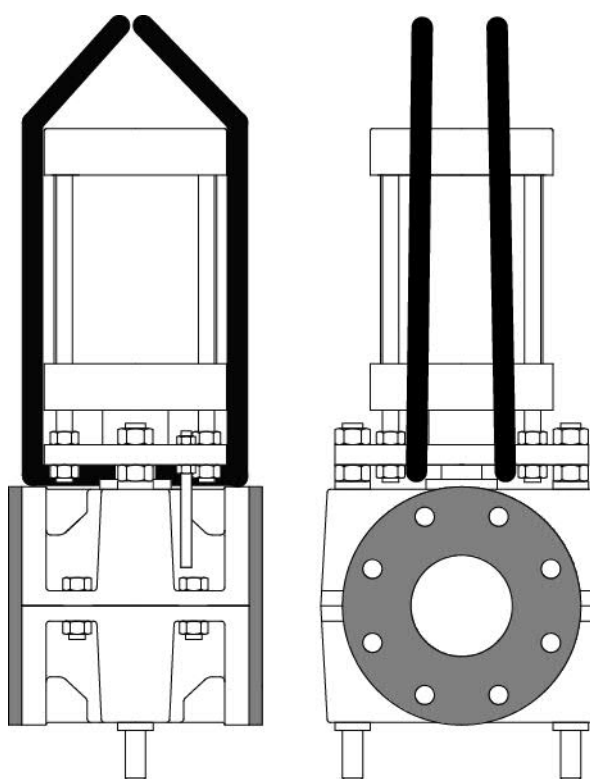

Figure 9. Lifting PVE Pneumatic valve

5 INSTALLATION

5.1 Open body model (PV)

The sleeve has not been designed to withstand axial forces. The pipes must therefore be supported properly so that neither tension nor compression is caused. Use cross-tightening for flange bolts. Do not overtighten bolts.

Make sure that no inappropriate items get between the pinch bars and the sleeve.

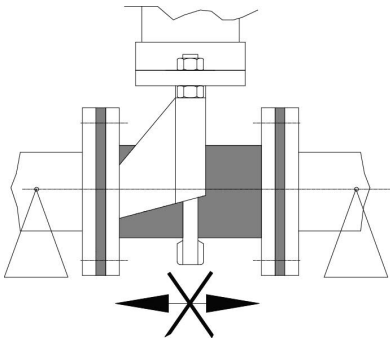

Figure 10.

If possible, protect the sleeve from direct sunlight. Direct sunlight and UV light deteriorate certain rubber qualities; this must also be considered during normal use.

A lengthwise angle deviation of max. 5° in the pipe is allowed (Figure 11).

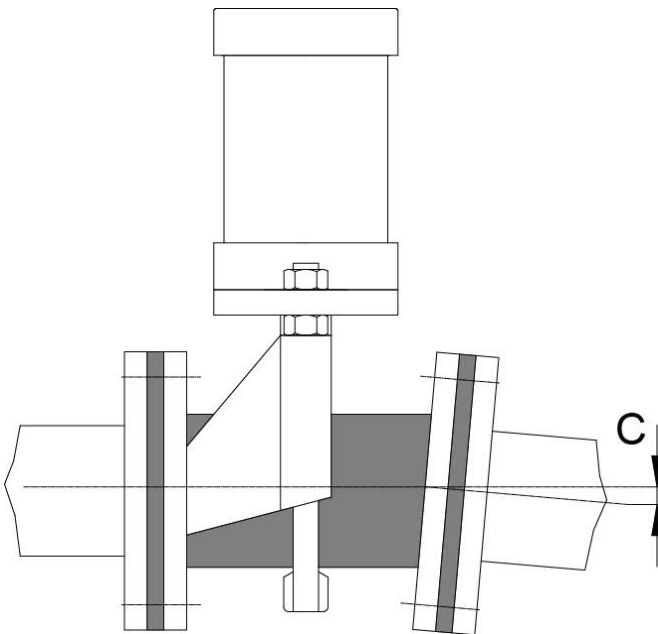

Figure 11.

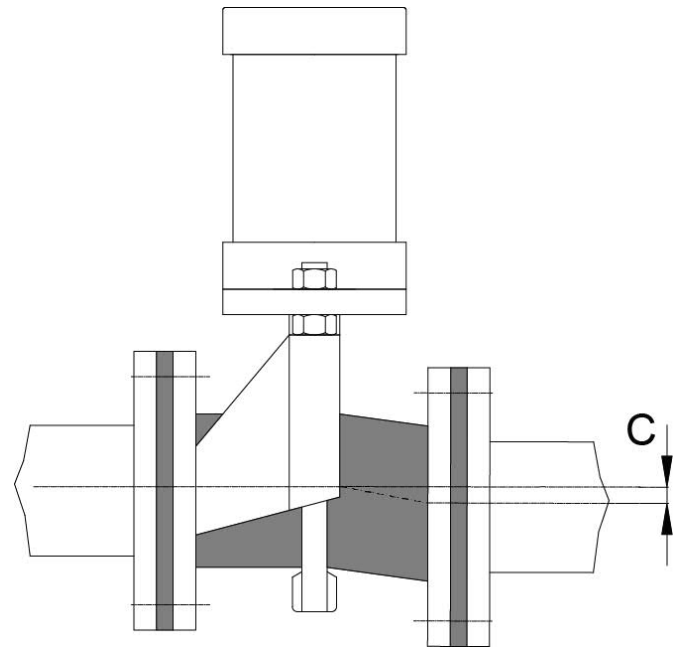

Figure 12.

Deviation in the centre line of the pipe (C), (Figure 12):

Size DN (in)	Dimension
PV 80...100 (3...4)	max. 5 mm (0.2 in)
PV 125...250 (5...10)	max.10 mm (0.4 in)
PV 300...500 (12...20)	max. 15 mm (0.6 in)
PV 550...1000 (22...40)	max. 20 mm (0.8 in)

5.2 Enclosed body model (PVE and PVE/S)

Make sure that no inappropriate items get between the valve body and the actuator.

5.3 All models (PV, PVE and PVE/S)

The actuator in all models (PV, PVE and PVE/S raises) 0.5 x valve nominal diameter. Allow enough headroom for installation and operation.

The valve nominal size means the inner diameter of the sleeve. The pipe inner diameter should match this diameter as closely as possible. Whenever possible, install the actuator in

a vertical position. Valve can be assembled either way in terms of flow direction.

If the valve must be installed horizontally, the actuator must be supported to ensure the smooth operation, especially if the actuator is heavy. Install a sliding surface under the actuator (Figure 13).

The support can be fixed on the wall (1), on the floor (2) or the pipeline (3).

The valve can be installed in either way depending on the flow direction.

When installing the valve to the pipeline, it must be in the open position. Tighten the flange bolts smoothly crosswise.

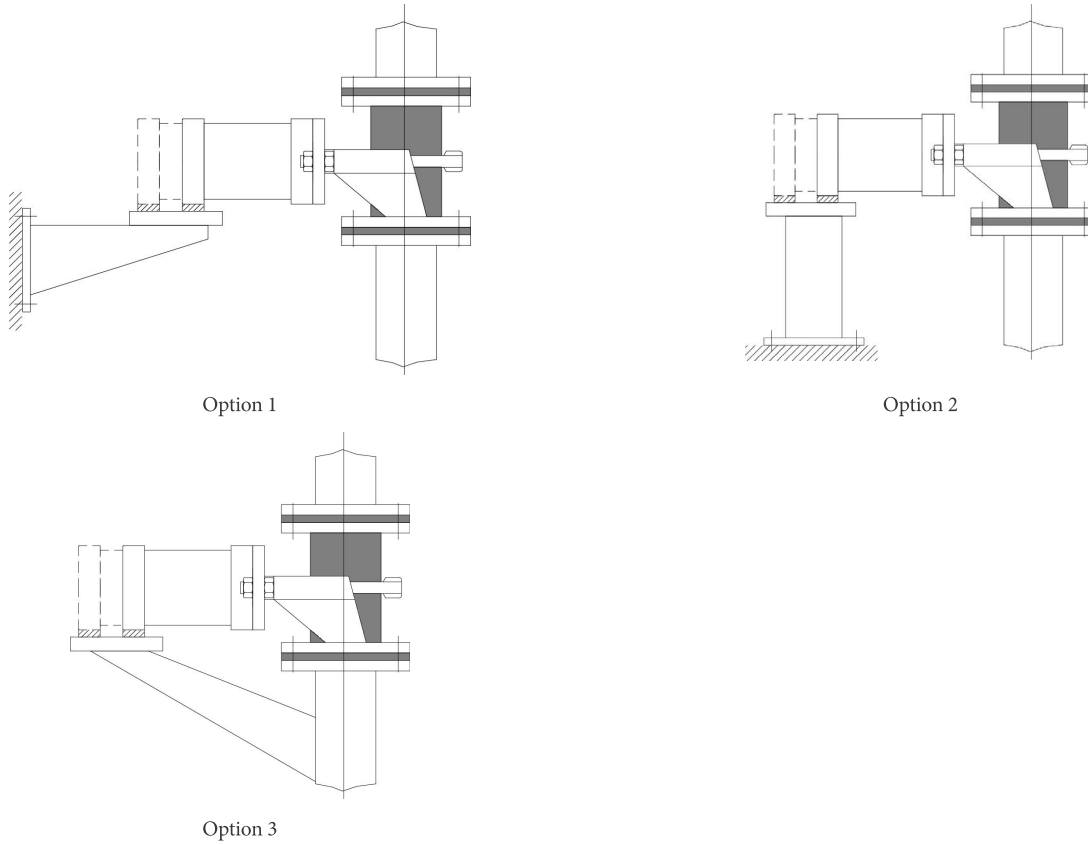



Figure 13. Support options.

	<p>Do not fasten actuator or any part of it to the support.</p>
--	---

Recommended flange compression values are shown in the table.

Valve size (DN)	Flange type 1 mm (in)	Flange type 3 mm (in)
25 - 65 (1" - 2.5")	1.5 (0.06)	2 (0.08)
80 - 100 (3" - 4")	2 (0.08)	2.5 (0.10)
125 - 150 (5" - 6")	2.5 (0.10)	3 (0.12)
200 (8")	3 (0.12)	3.5 (0.14)
250 - 700 (10" - 28")	-	3.5 (0.14)
750 - 1000 (30" - 40")	-	4 (0.16)

The sleeve sealing performance depends on several factors including media temperature, flange alignment, sleeve material and allowed tolerances. If leakage is detected, tighten the flange bolts reasonably until leakage is decreased to an acceptable

minimum.

6 OPERATION

6.1 First use

Flowrox valves are normally delivered fully assembled and ready to use. Check the condition of the valve visually.

After installation to the pipeline, check that all connections are leak-proof.

6.2 During operation

During the operation the valve does not normally require any maintenance. The sleeve change is described in 7.2.

To ensure smooth operation, it is recommended to change the valve sleeve regularly.

Regarding the actuators, follow the instructions of the manufacturer.

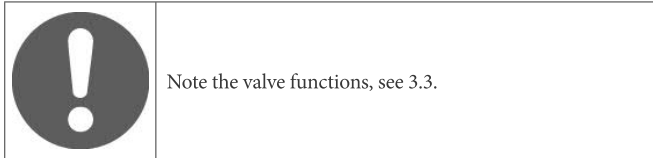



7 MAINTENANCE

7.1 Schedule

The sleeve is the only part of the valve which is in contact with the medium flowing in the pipeline. With regular sleeve changing, the likelihood of malfunctions in the process decreases. Wear resistance of the sleeve depends on the circumstances of the process and may vary a lot.

If there is a flow through closed valve or leakage through bushings (PVE) or through damaged sleeve (PV), change the sleeve immediately.

	 CAUTION!
	Harmful substance hazard. The process medium can be corrosive or harmful. PVE: In case of a sleeve failure, slight leakage can occur through bushings. PV: In case of a sleeve breakage, the flowing liquid will leak into the environment. Make sure the process medium is led to a safe location.

7.2 Changing the valve sleeve

	Control the valve functions (see 3.3) and follow the instructions for adjusting of valve (7.3) to prevent accidents and to ensure the correct operation of the valve.
--	---

Changing the valve sleeve in open model valve (PV)

See Figure 1 for part numbers.

1. Open the valve and detach it from the pipeline.
2. If the valve is equipped with opening tags, loosen the fixing screws (8 pcs) at the pinch bars and pull out the opening tags (Figure 14.).

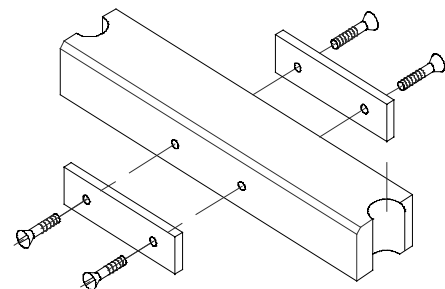

Figure 14.

3. Remove the broken sleeve by bending the rubber flange of the sleeve and by wrenching it with a pry bar or bending iron.
4. Put in the new sleeve by pressing the rubber flanges on the opposite sides together and push its edge as far as possible through the steel flange.
5. Wrenching the rest of the sleeve through the flange with a pry bar / bending iron (see Figure 15.).

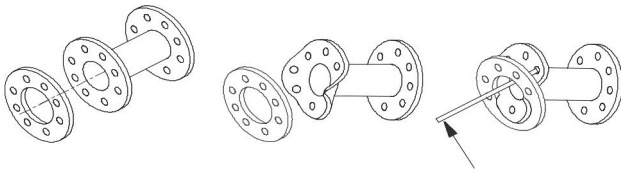
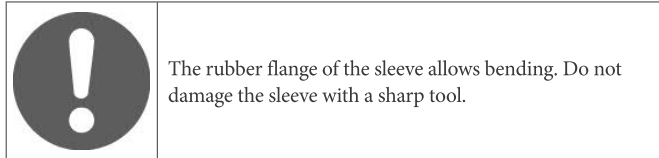
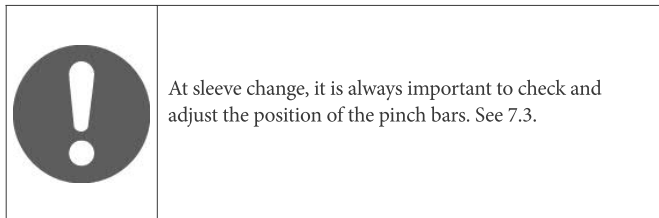

Figure 15.

6. After putting in the new sleeve, fix the opening tags to the pinch bars. The excessive length of the tags can be cut away.
7. Adjust the pinch bars before installing to the pipeline.



Changing valve sleeve of Enclosed model valve PVE

See Figure 2 for part numbers.

1. Open the valve and detach it from the pipeline.
2. Open the screws (7.) between the valve body halves and detach the lower part of the body. If the valve has opening tags, detach them (17.) from upper (3.) and lower pinch bars (4.), 8 pcs screws (Figure 14).
3. Take out the damaged sleeve and put in a new one. If the sleeve is stiff, detach the lower pinch bar.
4. Clean all the parts which have been in contact with the process medium.
5. Put in a new sleeve. Remember to fix the opening tags if applicable.

6. Check the body sealing (16.) between the body halves and the condition of the bushings (5.).

A worn sealing or worn bushings can cause leakage to the environment in the event of a sleeve breakage.

7. Assemble the valve and adjust the pinch bars before installing the valve to the pipeline.

Changing valve sleeve of Enclosed/Sealed model valve PVE/S

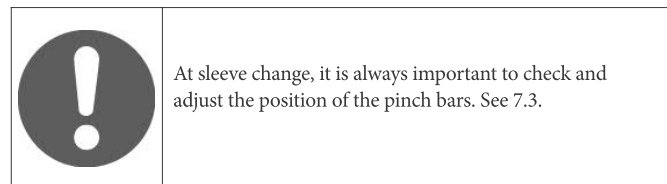

See Figure 3 for part numbers.

1. Open the valve and detach it from the pipeline.
2. Open the screws (part 7) between the valve body halves and detach the lower part of the body.
3. If the valve has opening tags (part 17), detach them from both upper and lower pinch bars, 8 pcs screws.
4. Take out the damaged sleeve and put in a new one. If the sleeve is stiff, loosen nuts (part 9) and take the sleeve out. If it is still impossible to remove the sleeve, detach the lower pinch bar by pulling it smoothly out and ensuring not to damage the seals (part 20, 21) with threads of lower pinch bar.
5. Clean all the parts which have been in contact with the process medium.
6. Put in a new sleeve. Remember to fix the opening tags if applicable.
7. Check the condition of the side bushings (parts 5). Replace the body sealing (part 16) between the body halves and the seals (part 20, 21) and the seal in the center bushing (part of actuator). A worn sealing and/or worn bushings may cause leakage to the environment in the event of a sleeve breakage.
8. Assemble the valve and adjust the pinch bars before installing the valve to the pipeline.



7.3 Adjusting the valve

After every sleeve change, the closing of the valve has to be checked and adjusted. A wrong adjustment may shorten the lifetime of the sleeve and cause leakage from the valve when the actuator is in the closed position.

	 WARNING!
	<p>Crushing and cutting hazard.</p> <p>Do not put your hands or fingers between the moving parts when the valve cycles. Do not energize the actuator before the valve is properly attached to the pipeline. Disconnect and de-energize the actuator before installation and maintenance work.</p>

Before reinstallation of the valve into the pipeline:

9. Close the valve with the actuator.
10. Adjust the pinch bars parallel to each other with the nuts, which are on both sides of actuator fixing plate (Figure 16, nuts 1 and 2). From one end of the sleeve an even, narrow light strip should be visible on the whole squeezed section of the sleeve or symmetrically on both sides (Figure 16 and Figure 17, dimension X).
11. Tighten both nuts (1) equally so, that the strip of light disappears (Figure 18). Loosen the lower nuts (2) if necessary.
12. Set the lower nuts (Figure 19, nut 2) Y mm from the attachment plate (see the dimensions Y in Table 2).
13. When the nuts (nut 1) on the upper side of the attachment plate are tightened, the lower pinch bar rises and causes a sufficient squeeze on the sleeve to close the flow against the pressure in the pipeline.
14. After this has been done, open the valve and it is ready to be installed to the pipeline.

If the valve is hand wheel operated, it is enough to check that the pinch bars are parallel, and the light slit is shown (Figure 16 and Figure 17, dimension X).

A sufficient squeeze is achieved by turning the hand wheel 1/3...3/4 rounds after the valve feels tight.

Table 1. Tightening values for manual valves

Pipeline pressure	Needed rotations
1 bar (15 psi)	appr. 1/3 of a hand wheel rotation
PN 10 bar (150 psi)	appr. 1/2 of a hand wheel rotation
PN 25 bar (375 psi)	appr. 3/4 of a hand wheel rotation

If the valve is supplied with a reduction gear, the number of rotations is multiplied by the gear ratio.

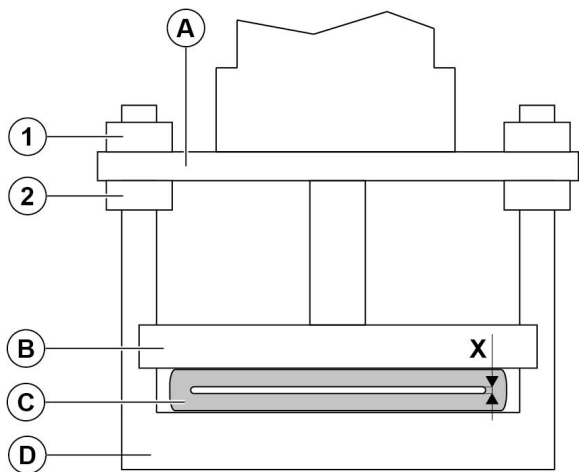

Figure 16.

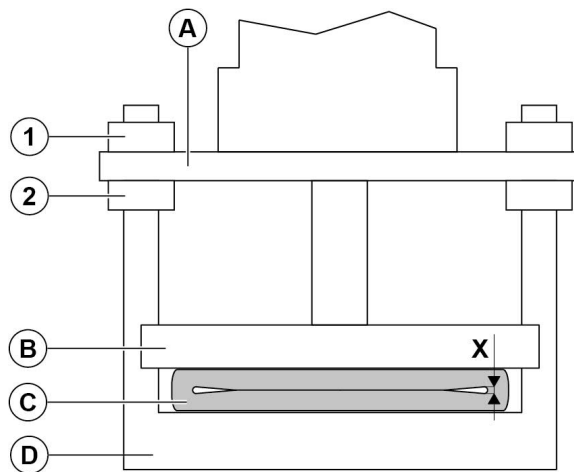

Figure 17.

Part	Description	Part	Description
A	Attachment plate	C	Sleeve
B	Upper pinch bar	D	Lower pinch bar

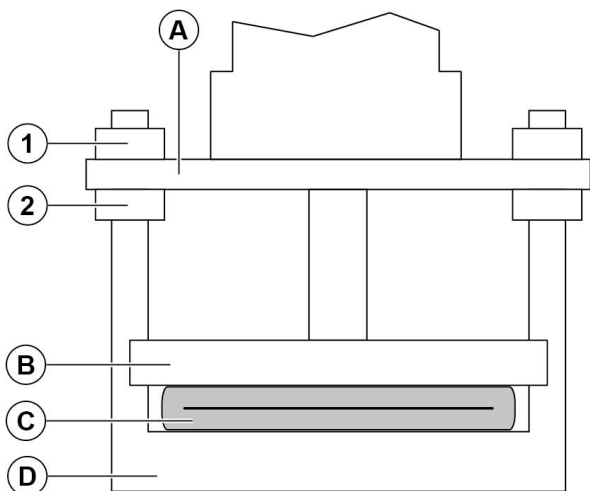

Figure 18.

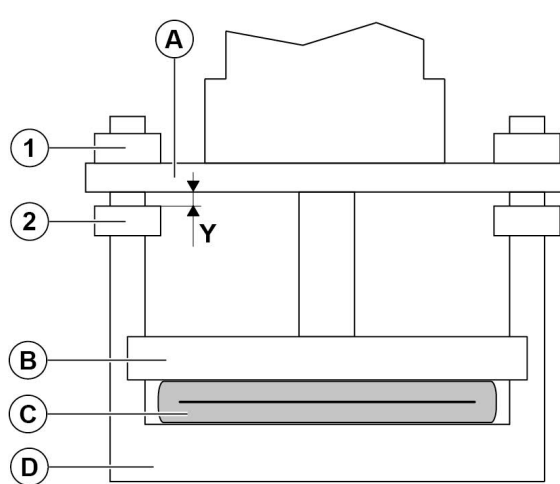

Figure 19.

Table 2. Dimension Y mm (in)

VALVE SIZE mm (in)	PRESSURE CLASS (Bar)		
	1	6...10	16...25
25...100 (1...4)	1,5 (0,06)	2.5 (0,10)	3.5 (0,14)
125...250 (5...10)	2,0 (0,08)	3.0 (0,12)	4.0 (0,16)
300...500 (12...20)	3,0 (0,12)	4.0 (0,16)	
550...(22...)	4,0 (0,16)		

Use the tightening torques on the table if no specific torque is given.

Table 3. General tightening torques for screws

Size	Tightening torques	
	Nm (ft-lbs) ±5%	
	Bolt strength class (lubrication conversion factor 0,86) MoS2	
	8.8	A4-80
M6	8 (6)	8 (6)
M8	21 (15)	19 (14)
M10	40 (30)	38 (28)
M12	70 (51)	65 (48)
M16	169 (125)	161 (119)
M20	331 (244)	313 (231)
M24	572 (422)	541 (399)
M27	827 (610)	782 (577)
M30	1127 (831)	1067 (787)
M33	1522 (1123)	1437 (1060)
M36	1961 (1446)	1858 (1370)

7.4 Troubleshooting

PROBLEM	POSSIBLE REASON	ACTION
Valve leaks into the environment.	1. Sleeve breakage. 2. End flanges loosely tightened.	1. Change and make adjustment of sleeve 2. Tighten the flange end screws
Leakage or flow through the valve when valve should be closed.	Sleeve breakage.	(models PVE, PVS): check by the plug - change and make adjustment of sleeve
	Sleeve is not closed with sufficient squeeze.	Manual valves - turn the hand wheel more tight. Pneumatic and hydraulic actuators - check the supply pressure for cylinder; if the pressure is too low, the sufficient squeeze for the sleeve cannot be reached. Check the compactness of the cylinder seals.
	Wrong adjustment of the sleeve.	Make the adjustment
Shorter lifetime of the sleeve than before.	Sleeve is not closed with sufficient squeeze.	Manual valves - turn the hand wheel more tight. Pneumatic and hydraulic actuators - check the supply pressure for cylinder; if the pressure is too low, the sufficient squeeze for the sleeve cannot be reached. Check the compactness of the cylinder sealings.
	Wrong adjustment of the sleeve.	Make the adjustment.
	1. Pneum. valves: wrong adjustment of the end cushioning in front end-block of cylinder. 2. Wrong adjustment of the pneum. spring.	1. End cushioning in front end-block of cylinder should be fully open. 2. Check adjustment of pneumatic spring .
	Changes in customer process e.g. composition of medium / temperature flow capacity	Check the best rubber quality with Valmet Flow Control Oy. Select another valve size with Valmet Flow Control Oy (particularly valves with positioners).
Sleeve is flapping and/or flow capacity is not sufficient.	Vacuum or pressure shocks in pipeline, rubber has hardened and does not open totally.	Check that the opening tags are fixed.

In case you cannot find the solution to your problem in the above table, please turn to the nearest Valve Flow Control Oy representative. The serial number and type identification of the valve in question will help getting the prompt answer.

APPENDIX A: DIMENSIONS

PV valve, Manual actuator

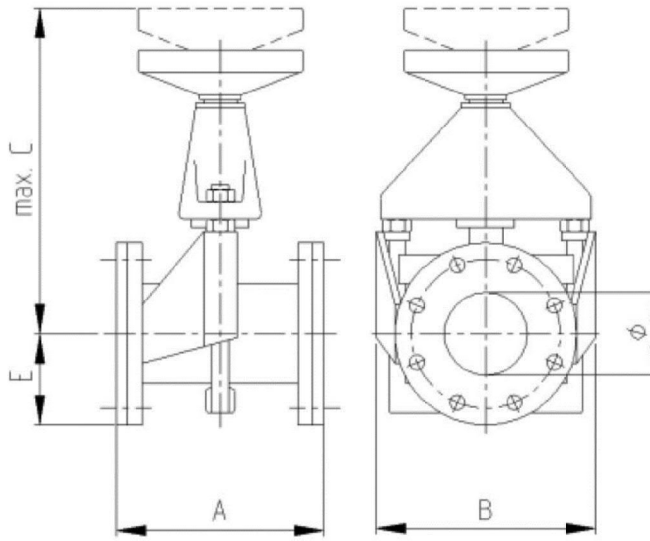

PV valve, Pneumatic actuator

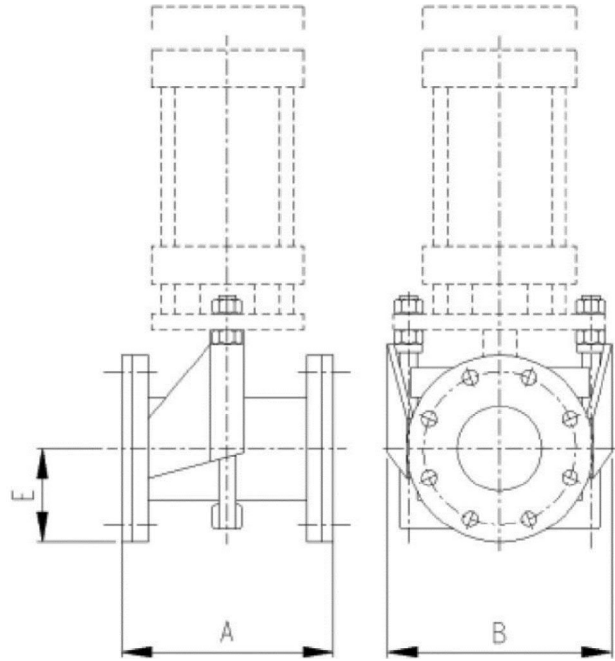

Valve size (PV) M&A	PN (bar)	A	B	C	E	Weight Manual valves (kg)	Weight Automatic valves (kg)
80	1-25	200	235	370	100	22	14
100	1-25	250	265	410	110	29	16
125	1-25	310	325	465	135	46	23
150	1-16	375	381	560	143	67	36
200	1-16	500	461	690	170	88	47
250	1-10	625	545	865	210	137	85
300	1-6	750	704	1020	250	167	100

Valve size (PV) M&A	PN (psi)	A	B	C	E	Weight Manual valves (lb)	Weight Automatic valves (lb)
3	15-375	7.9	9.3	14.6	3.9	49	31
4	15-375	9.8	10.4	16.1	4.3	64	36
5	15-375	12.2	12.8	18.3	5.3	102	51
6	15-240	14.8	15.0	22.0	5.6	148	80
8	15-240	19.7	18.1	27.2	6.7	194	104
10	15-145	24.6	21.5	34.1	8.3	302	188
12	15-90	29.5	27.7	40.2	9.8	368	221

PVE/S valve, Manual actuator

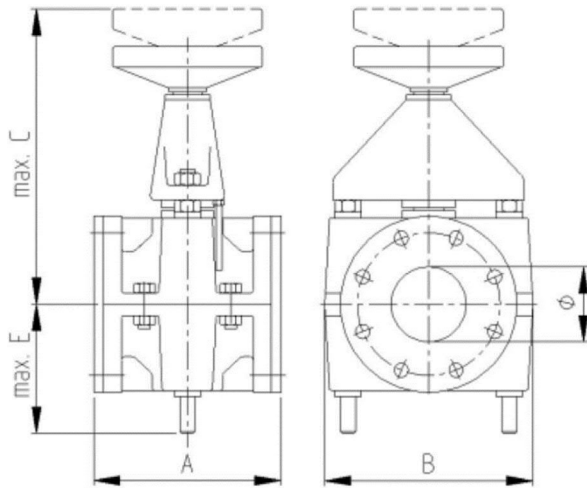

PVE/S valve, Pneumatic actuator

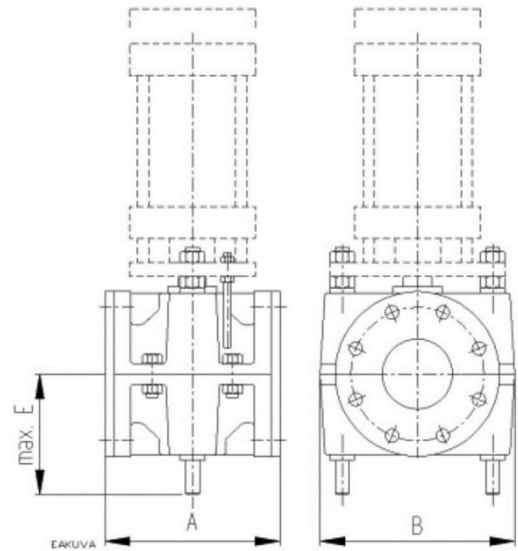

Valve size (PVE) M&A	PN (bar)	A	B	C	E	Weight Manual valves (kg)		Weight Manual valves (kg)	
						FE	AL	FE	AL
25	1-25	165	125	255	87	11	7	8	4
32	1-25	165	140	260	90	14	9	10	5
40	1-25	165	180	265	105	16	9	12	6
50	1-25	165	190	280	120	18	9	13	7
65	1-25	165	210	310	136	22	12	17	9
80	1-25	200	245	370	155	36	17	27	13
100	1-25	250	278	410	175	46	25	33	17
125	1-25	310	340	465	210	74	41	48	25
150	1-16	375	400	560	240	106	74	75	43
200	1-10	500	480	690	295	159	-	119	-
250	1-6	625	570	865	380	213	-	161	-
300	1	750	720	1020	445	279	-	212	-

Valve size (PVE) M&A	PN (psi)	A	B	C	E	Weight Manual valves (lbs)		Weight Automatic valves (lbs)	
						FE	AL	FE	AL
1	15-375	6.5	5.0	10.1	3.4	25	16	18	9
1.25	15-375	6.5	5.5	10.2	3.5	31	20	22	11
1.5	15-375	6.5	7.1	10.4	4.1	36	20	27	14
2	15-375	6.5	7.5	11	4.7	40	20	29	16
2.5	15-375	6.5	8.3	12.2	5.4	49	27	38	20
3	15-375	8	9.6	14.6	6.1	80	38	60	29
4	15-375	10	10.9	16.1	6.9	102	55	73	38
5	15-375	12.2	13.4	18.3	8.3	163	91	106	55
6	15-240	14.8	15.7	22	9.4	234	163	166	95
8	15-150	19.7	18.9	27.2	11.6	351	-	263	-
10	15-90	24.6	22.4	34.1	15	470	-	355	-
12	15	29.5	28.3	40.2	17.5	615	-	468	-

APPENDIX B: HOW TO ORDER

1.	2.	3.	4.	5.	6.	7.	8.	9.	10.	11.	12.
PVE	300	A	10	-	2	0	3	L	R2Z3	,	SBRT

1.	Product type
PV	Open
PVE	Enclosed
PVE/S	Enclosed /sealed
PVS	Sealed

2.	Product size DN
25..600	Conical mark with directly with conical reduction Example 50-40

3. ACTUATOR															
A PNEUMATIC						E ELECTRIC					H HYDRAULIC		MG MANUAL		
CYLINDER		MANUAL OVERRIDE		POSITIONER		OPTIONS		TYPE		VOLTAGE RANGE		TYPE		TYPE	
A	Pneumatic cylinder	-	NONE	-	NONE	-	NONE	E	Electric On-Off AUMA Norm	-	400V/50hz	H	Hydraulic	M	Manual handwheel
A1S	Pneumatic with stainless piston rod, tie rods and painted cylinder	B	Manual override	K	Positioner Neles ND9000 series	U1C	With pneumatic spring FAIL CLOSE	EP	Electric On-Off with feedback unit EWG 01.1, AUMA	B	380V/50hz	HA	Intergated Solenoid valve 24 VDC	MG	Manual with bevel gear
A2S	Pneumatic "Stainless" no painting			KF	With integrated (Festo DFPI) positioner a)	U1O	With pneumatic spring FAIL OPEN	ES	Electric On-Off AUMA-Matic	C	440V/50hz	HB	Intergated Solenoid valve 110VAC	MCW	Chainwheel
				KL	Standard Positioner with special auxiliaries or other brand than Flowrox Selected Standard	U2C	With pneumatic spring (Pressure switch) FAIL CLOSE c)	EO	Electric On-Off with positioner, Aumatic	D	525V/50hz	HC	Intergated Solenoid valve 230VAC		
						U2O	With pneumatic spring (Pressure switch) FAIL OPEN c)	EL	Electric (Other)	E	460V/60hz	HP	Hydraulic positioner		
						VC	With mechanical spring FAIL CLOSE			N	Other	HL	Other		
						VO	With mechanical spring FAIL OPEN								

4.	Pressure class PN
4	4 bar / 60 psi
6	6 bar / 90 psi
10	10 bar / 150 psi
16	16 bar / 240 psi
25	25 bar / 375 psi
40	40 bar / 600 psi
64	64 bar / 960 psi
100	100 bar / 1500 psi

6.	Flange drilling
2	DIN PN 10
3	DIN PN 16
4	DIN PN 25
5	DIN PN 40
6	ASME B16.5 Class 150
7	ASME B16.5 Class 300
8	BS TABLE D
9A	AS TABLE D
9B	AS TABLE E
9C	JIS 10
9D	JIS 16
9	OTHER

7.	Body material
0	Cast iron / Fe
2	AISI 316
3	Aluminium
4	Other
5	Polyurethane / polyamide

8.	Flange type
	Type 1
	Type 3
	Type 4
	Determined by the valve Flowrox

10.	Auxiliaries			
	Description	Extra info	Applicable actuator	
B	Pressure Booster in air supply	Pressure booster determined by Flowrox, used to increase the supply air pressure to secure enough force for pneumatic cylinder.	PNEUMATIC	*
F	Filter Regulator + gauge	Filter Regulator + Gauge Flowrox selected model.	PNEUMATIC	*
F1	Filter Regulator + gauge (stainless steel AISI 316)	Filter Regulator + Gauge Flowrox selected model. FESTO PCR P G1/4 & G1/2		*
F5	Filter Regulator OR Filter Regulator+ gauge	Filter Regulator OR Filter Regulator+ gauge (Non-standard)	PNEUMATIC	
H	Hydraulic Handpump (For Hydraulic only)	Manual hydraulic handpump for hydraulic actuators H only.	PNEUMATIC	*

10.	Auxiliaries			
	Description	Extra info	Applicable actuator	
J1	Junction box small (Flowrox Standard)	Junction box small, for limit switches or solenoid valve, IP66, plastic, 2 pcs M12x1.5 and 1 pc M20x1.5, pre-wired.	HYDRAULIC	*
J2	Junction box large (Flowrox Standard)	Junction box large, for limit switches and solenoid valve, IP66, plastic, 4 pcs M12x1.5 and 1 pc M20x1.5, pre-wired.	ANY	*
J4	Junction Box (Non-Standard)	Junction box out of Flowrox standard scope specification clarified on the proposal and under valve serial number.	ANY	
P1	Stainless steel fittings + Corrosion resistant tubing	High temperature & corrosion resistance	ANY	
P2	AISI 316 Fitting and piping	Stainless steel fitting and piping	PNEUMATIC	
Q	Quick exhaust valve	Quick exhaust valve to maximize the speed of cylinder.	PNEUMATIC	*
R	Readiness for ind. Limit switches	Readiness for d18mm inductive limit switches.	PNEUMATIC	*
R1	AC/DC (18mm cylindrical switch) (Flowrox Standard)	AC/DC,2-wire type,(24...240VAC / 24...240VDC) Flowrox selected model	ANY	*
R2	DC, PNP (18mm cylindrical switch) (Flowrox Standard)	DC,3-wire type, PNP (12...24V) Flowrox selected model	ANY	*
R3	DC, NPN (18mm cylindrical switch) (Flowrox Standard)	DC,3-wire type, NPN (12...24V) Flowrox selected model	ANY	*
R5	Limit switch (Non-Standard)	Limit switch out of Flowrox standard scope specification clarified on the proposal and under valve serial number.	ANY	
S	Magnetic limit switches (Flowrox Standard)	Magnetic limit switches, attached to aluminium pneumatic cylinder actuators. Cylinder fitted with magnetic piston.	ANY	*
S5	Magnetic limit switches (NON-Standard)	Magnetic limit switches, attached to aluminium pneumatic cylinder actuators. Cylinder fitted with magnetic piston.	PNEUMATIC	*
T	Mechan. Limit switches (Flowrox Standard)	Mechanical limit switches Flowrox selected model	ANY	
T5	Mechan. Limit switches (NON-Standard)	Mechanical limit switches (Non-standard) Consult with Flowrox	ANY	
Z1	Solenoid valve, 24VDC, Monostable (Flowrox Standard)	Solenoid valve 24 VDC (for pneumatic actuator) with necessary tubing Flowrox selected model, monostable (Single coil).	PNEUMATIC	*
Z1B	Solenoid valve, 24VDC, Bistable (Flowrox Standard)	Solenoid valve 24 VDC (for pneumatic actuator) with necessary tubing Flowrox selected model, Bistable (Double coil).	PNEUMATIC	*
Z2	Solenoid valve, 230V, 50/60Hz, Monostable (Flowrox Standard)	Solenoid valve 230V - 50/60Hz (for pneumatic actuator) with necessary tubing Flowrox selected model, monostable (Single coil).	PNEUMATIC	*
Z2B	Solenoid valve, 230V, 50/60H, Bistable (Flowrox Standard)	Solenoid valve 230V - 50/60Hz (for pneumatic actuator) with necessary tubing Flowrox selected model, Bistable (Double coil).	PNEUMATIC	*
Z3	Solenoid valve, 110V, 50/60Hz, Monostable (Flowrox Standard)	Solenoid valve 110V, 50/60Hz (for pneumatic actuator) with necessary tubing Flowrox selected model, monostable (Single coil).	PNEUMATIC	*
Z3B	Solenoid valve, 110V, 50/60Hz,Bistable (Flowrox Standard)	Solenoid valve 110V, 50/60Hz (for pneumatic actuator) with necessary tubing Flowrox selected model Bistable (Double coil).	PNEUMATIC	*
Z5	Solenoid valve, 24VDC, Monostable (Non-Standard)	24 VDC monostable (Single coil) solenoid valve out of Flowrox standard scope specification clarified on the proposal and under valve serial number.	PNEUMATIC	
Z5B	Solenoid valve, 24VDC, Bistable (Non-Standard)	24 VDC Bistable (Double coil) solenoid valve out of Flowrox standard scope. To be specified on the proposal and under valve serial number.	PNEUMATIC	
Z6	Solenoid valve, 230V, 50/60Hz, Monostable (Non-Standard)	230V 50/60Hz monostable (Single coil) solenoid valve out of Flowrox standard scope. To be specified on the proposal and under valve serial number.	PNEUMATIC	
Z6B	Solenoid valve, 230V, 50/60H, Bistable (Non-Standard)	230V 50/60Hz Bistable (Double coil) solenoid valve out of Flowrox standard scope. To be specified on the proposal and under valve serial number.	PNEUMATIC	
Z7	Solenoid valve, 110V, 50/60Hz, Monostable (Non-Standard)	110V 50/60Hz monostable (Single coil) solenoid valve out of Flowrox standard scope. To be specified on the proposal and under valve serial number.	PNEUMATIC	
Z7B	Solenoid valve, 110V, 50/60Hz,Bistable (Non-Standard)	110V 50/60Hz Bistable (Double coil) solenoid valve out of Flowrox standard scope. To be specified on the proposal and under valve serial number.	PNEUMATIC	

10.	Auxiliaries		
	Description	Extra info	Applicable actuator
X	Must be specified	Additional auxiliary equipment not listed.	ANY

* Flowrox standard options

12.	Sleeve material
SBRT	Styrene Butadiene rubber
EPDM	Ethylene propylene diene monomer
NR	Natural rubber
NBR	Nitrile
CSM	Hypalon
EPDMB	Green liquor sleeve
CR	Chloroprene
IIR	Butyl
NRF	Foodstuff natural rubber
NBRF	Foodstuff nitrile
HNBR	Hydrogenated nitrile
FPM	Fluorine rubber
Additional features:*	
/M	Flowrox SensoMate sleeve
/PU	PU-coating inside the sleeve
/VAC	Vacuum sleeve

Valmet Flow Control Oy

Marsitie 1, 53600 Lappeenranta, Finland.

Tel. +358 10 417 5000

www.valmet.com/flowcontrol

Subject to change without prior notice.

Neles, Neles Easyflow, Jamesbury, Stonel, Valvcon and Flowrox, and certain other trademarks, are either registered trademarks or trademarks of Valmet Oyj or its subsidiaries in the United States and/or in other countries.

For more information www.neles.com/trademarks

