



82 Uncompensated

SPECIFICATIONS

- **316L SS Pressure Sensor**
- **19mm Diameter Package**
- **0 - 100mV Output**
- **Absolute and Gage**

The 82 uncompensated is a 19 mm small profile, media compatible, piezoresistive silicon pressure sensor packaged in a 316L stainless steel housing. The 82 uncompensated can be configured for o-ring mounting or threaded process fittings and is designed for OEM applications where compatibility with corrosive media is required.

The sensing package utilizes silicone oil to transfer pressure from the 316L stainless steel diaphragm to the sensing element.

Please refer to the 82 compensated and constant voltage datasheets for more information on different features of the 82.

FEATURES

- O-Ring Mount/Threaded Process Fittings
- -40°C to +125°C Operating Temperature
- Up to $\pm 0.1\%$ Pressure Non Linearity
- Solid State Reliability

APPLICATIONS

- Medical Instruments
- Process Control
- Fresh & Waste Water Measurements
- Partial Vacuum Gas Measurement
- Pressure Transmitters
- Tank Level Systems (RV & Industrial)

STANDARD RANGES

Range	psia	psig
0 to 1		•
0 to 5	•	•
0 to 15	•	•
0 to 30	•	•
0 to 50	•	•
0 to 100	•	•
0 to 300	•	•
0 to 500	•	•

PERFORMANCE SPECIFICATIONS

Supply Current: 1.5mA

Ambient Temperature: 25°C (unless otherwise specified)

PARAMETERS	001PSI			005PSIA			005PSIG & ≥015PSI			UNITS	NOTES
	MIN	TYP	MAX	MIN	TYP	MAX	MIN	TYP	MAX		
Sensitivity	9		20	12	15	18	12		27	mV/V@FS	
Zero Pressure Output	-4		8	-10		10	-6		8	mV/V	1
Pressure Non Linearity	-0.3		0.3	-0.2		0.2	-0.1		0.1	%Span	2
Pressure Hysteresis	-0.10		0.10	-0.10		0.10	-0.05		0.05	%Span	3
Repeatability		±0.02			±0.02			±0.02		%Span	
Bridge Resistance	4.4	5.8	6.2	4.0	5.0	6.0	3.8		5.8	KΩ	4
Thermal Hysteresis – Span	-0.25	±0.05	0.25	-0.25	±0.05	0.25	-0.25	±0.05	+0.25	%Span	5
Thermal Hysteresis – Offset	-0.25	±0.05	0.25	-0.25	±0.05	0.25	-0.25	±0.05	+0.25	%Span	5
Temp. Coefficient – Resistance	2.60	3.20	3.50		2.40		1.30	1.51	1.75	kppm/°C	5
Temp. Coefficient – Span	-3.30	-2.80	-2.30		-2.00		-1.65	-1.25	-1.00	kppm/°C	5
Temp. Coefficient – Offset		±100		-80		80	-30		+30	μV/V/°C	3, 5
Long Term Stability – Span		±0.1			±0.1			±0.1		%Span	
Long Term Stability – Offset		±0.25			±0.25			±0.1		%Span	3
Supply Current	0.5	1.5	2.0	0.5	1.5	2.0	0.5	1.5	2.0	mA	
Supply Voltage		5	9.5		5	9.5		5	9.5	V	
Insulation Resistance (50Vdc)	50			50			50			MΩ	6
Output Noise (10Hz to 1KHz)		1			1			1		μV p-p	7
Response Time (10% to 90%)		0.1			0.1			0.1		ms	8
Pressure Overload			10x			3x			3x	Rated	
Pressure Burst			12x			4x			4x	Rated	
Operating Temperature	-40		+85	-40		+125	-40		+125	°C	
Storage Temperature	-50		+125	-50		+125	-50		+125	°C	
Media – Pressure Port	Liquids and Gases compatible with 316L Stainless Steel										

Notes

1. Measured at vacuum for absolute (A) and at ambient for gage (G).
2. Non-linearity is ±0.2 max for 5psi devices.
3. Values for 5psiG devices are as follows:
 Pressure Hysteresis: -0.10 min, +0.10 max
 Temp. Coefficient (Span): -80 min, +80 max
 Long Term Stability (Offset): ±0.25 typ
4. Bridge resistance is measured with both –E pins shorted together.
5. TC values are first order coefficients to a quadratic fit over a temperature range of -20°C to +85°C (0°C to 50°C for 1psi, 0°C to 70°C for 5psi).
6. Between case and sensing element.
7. The maximum pressure that can be applied without changing the transducer's performance or accuracy.
8. The maximum pressure that can be applied without rupture of either the sensing element or transducer.

Additional Notes

9. Standard gage units are not recommended for vacuum applications.
10. Direct mechanical contact with diaphragm is prohibited. Diaphragm surface must remain free of defects (scratches, punctures, dents, fingerprints, etc.) for device to operate properly. Caution is advised when handling parts with exposed diaphragms. Use protective cap whenever the devices are not in use.

DIMENSIONS

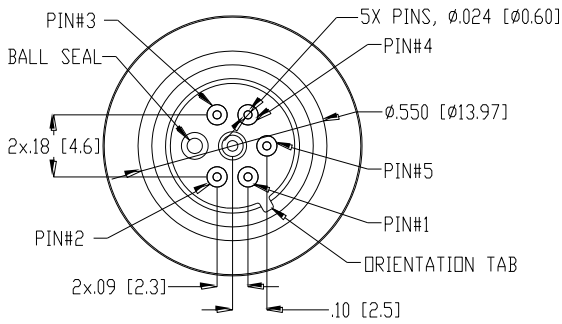
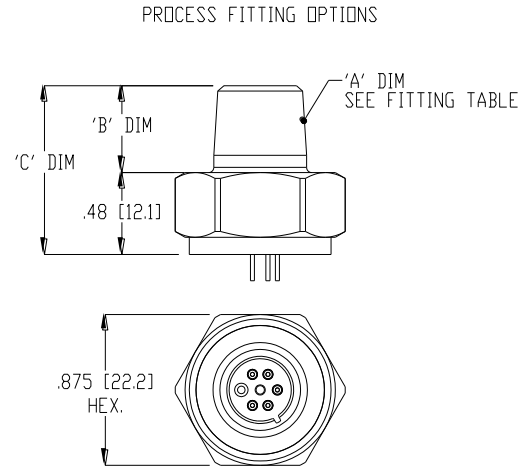
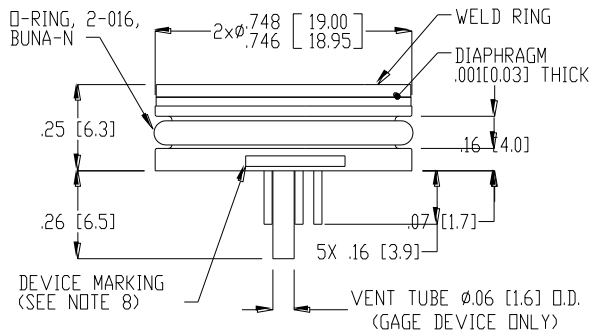

FITTING TABLE				
FITTING TYPE	MEMS P/N	'A' DIM	'B' DIM	'C' DIM
1	IC-7152	1/4-18 NPT	.50[12.7]	.98[24.9]
2	IC-D00510	1/8-27 NPT	.47[11.9]	.95[24.1]
3	IC-D00511	7/16-20 UNF	.33[8.4]	.80[20.3]
9	IC-D00512	1/4-19 BSP	.45[11.4]	.93[23.3]
NOTE: FITTING TYPE '1' ASSEMBLT SHOWN ALL DIMS ARE FOR REFERENCE.				

SENSOR PINDOUT	
PIN NO.	FUNCTION
1	-OUT
2	-EX2
3	+OUT
4	+EX
5	-EX1

DIMENSIONS ARE IN INCHES[mm]

CONNECTIONS

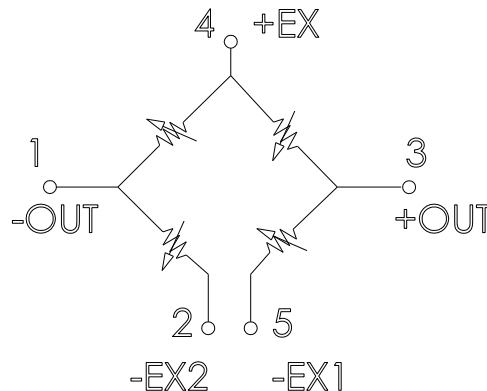

ORDERING INFORMATION

82	-	050	G	-	1	U	T
Model	-	Pressure Range	Pressure Type	-	Fitting Type	Electrical	Vent
82	-	001* 005 015 030 050 100 300 500	G = Gage A = Absolute	-	Blank = O-Ring Mount 1 = 1/4-18NPT 2 = 1/8-27 NPT 3 = 7/16-20UNF 9 = 1/4-19BSP	U = Open Bridge, Uncompensated	Blank = No Tube T = Tube

*1psi only available in gage type

NORTH AMERICA

Measurement Specialties, Inc.,
a TE Connectivity Company
45738 Northport Loop West
Fremont, CA 94538
Tel: 1-800-767-1888
Fax: 1-510-498-1578
Sales: pfg.cs.amer@meas-spec.com

EUROPE

Measurement Specialties (Europe), Ltd.,
a TE Connectivity Company
26 Rue des Dames
78340 Les Clayes-sous-Bois, France
Tel: +33 (0) 130 79 33 00
Fax: +33 (0) 134 81 03 59
Sales: pfg.cs.emea@meas-spec.com

ASIA

Measurement Specialties (China), Ltd.,
a TE Connectivity Company
No. 26 Langshan Road
Shenzhen High-Tech Park (North)
Nanshan District, Shenzhen 518057
China
Tel: +86 755 3330 5088
Fax: +86 755 3330 5099
Sales: pfg.cs.asia@meas-spec.com

TE.com/sensorsolutions

Measurement Specialties, Inc., a TE Connectivity company.

Measurement Specialties, TE Connectivity, TE Connectivity (logo) and EVERY CONNECTION COUNTS are trademarks. All other logos, products and/or company names referred to herein might be trademarks of their respective owners.

The information given herein, including drawings, illustrations and schematics which are intended for illustration purposes only, is believed to be reliable. However, TE Connectivity makes no warranties as to its accuracy or completeness and disclaims any liability in connection with its use. TE Connectivity's obligations shall only be as set forth in TE Connectivity's Standard Terms and Conditions of Sale for this product and in no case will TE Connectivity be liable for any incidental, indirect or consequential damages arising out of the sale, resale, use or misuse of the product. Users of TE Connectivity products should make their own evaluation to determine the suitability of each such product for the specific application.

© 2015 TE Connectivity Ltd. family of companies All Rights Reserved.