



Preliminary

MS5525ASO (Analog Small Outline)

SPECIFICATIONS

- **PCB Mountable Pressure Transducers**
- **Amplified Ratiometric Analog Output**
- **Differential, Gage, Absolute & Compound**
- **Temperature Compensated**
- **2.75 to 5.5 Vdc Supply Voltage**
- **Pressure Range: 1 to 30PSI**

The MS5525ASO is a small SOIC packaged, PCB mountable pressure transducer from Measurement Specialties for high volume OEM users. The transducer is built using Measurement Specialties' proprietary UltraStable process and the latest CMOS sensor conditioning circuitry to create a low cost, high performance transducer designed to meet the strictest requirements from customers.

The MS5525ASO is fully calibrated and temperature compensated with a total error band (TEB) of less than 2.5% over the compensated range. The sensor operates from a single supply of 5.0Vdc and requires a single external component for proper operation.

The small transducer is available in top straight port, top barb port and manifold mount and can measure absolute, gage, differential, or compound pressure from 1 to 30psi. The 1/10" barbed pressure ports mate securely with 3/32" ID x 7/32" OD x 1/16" wall thickness tubing.

FEATURES

- PSI Pressure Ranges
- PCB Mountable, Small Outline IC Package
- High Level Analog Output
- Barbed Pressure Ports

APPLICATIONS

- Factory Automation
- Altitude and Airspeed Measurements
- Medical Instruments
- Leak Detection

STANDARD RANGES

Pressure	Absolute	Gage	Differential	Compound
1		DB, SB, ST, DH	DB, DH	
2		DB, SB, ST, DH	DB, DH	
5		DB, SB, ST, DH	DB, DH	
15	SB, ST	DB, SB, ST, DH	DB, DH	SB, ST
30	SB, ST	DB, SB, ST, DH		

See Package Configurations: DB= Dual Barb Port, SB= Single Barb Port, ST= Single Tube Port, DH= Dual Hole
Contact factory for higher pressure ranges

BLOCK DIAGRAM

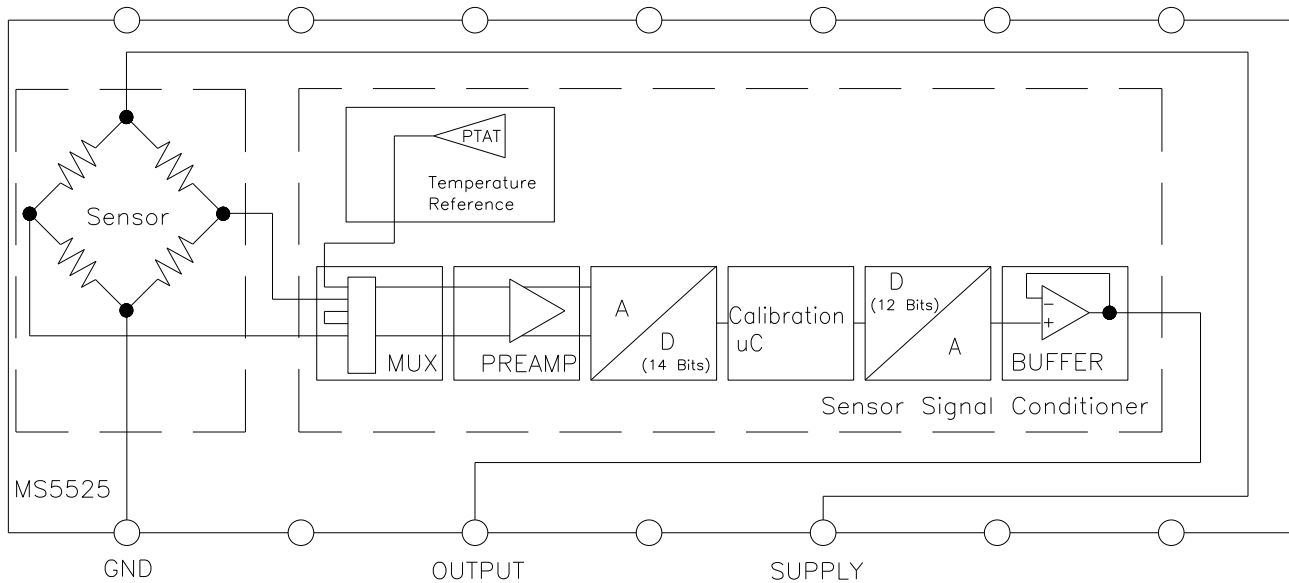

ABSOLUTE MAXIMUM RATINGS

Parameter	Conditions	Min	Max	Unit	Notes
Supply Voltage	T _A = 25 °C	2.7	5.5	V	
Output Current	T _A = 25 °C		3	mA	
Load Resistance (R _L)	T _A = 25 °C	10		kΩ	
Storage Temperature		-40	+125	°C	
Humidity	T _A = 25 °C		95	%RH	Non Condensing
Overpressure	T _A = 25 °C, both Ports		60	psi	
Burst Pressure	T _A = 25 °C, Port 1			psi	See Table 1
ESD	HBM	-4	+4	kV	EN 61000-4-2
Solder Temperature		250°C, 5 sec max.			

TABLE 1- BURST PRESSURE BY RANGE AND PACKAGE STYLE

Range	DS	TP, SS, MM	Unit
001	20	20	psi
002	20	20	psi
005	15	20	psi
015	60	60	psi
030	60	60	psi

ENVIRONMENTAL SPECIFICATIONS

Parameter	Conditions
Mechanical Shock	Mil Spec 202F, Method 213B, Condition C, 3 Drops
Mechanical Vibration	Mil Spec 202F, Method 214A, Condition 1E, 1Hr Each Axis
Thermal Shock	100 Cycles over Storage Temperature, 30 minute dwell
Life	1 Million FS Cycles
MTTF	>10Yrs, 70°C, 10 Million Pressure Cycles, 120 %FS Pressure

PERFORMANCE SPECIFICATIONS**Supply Voltage¹: 5.0V****Reference Temperature: 25°C (unless otherwise specified)**

PARAMETERS	MIN	TYP	MAX	UNITS	NOTES
Accuracy	-0.5		0.5	%Span	1, 2
Total Error Band (TEB)	-2.5		2.5	%Span	2, 5
Supply Current		3		mA	6
Compensated Temperature	-10		+85	°C	3
Operating Temperature	-25		+105	°C	
Update Time		1		mS	6
Weight		3		grams	
Media	Non-Corrosive Dry Gases Compatible with Ceramic, Silicon, Borosilicate Glass, PPS, RTV, Gold, Aluminum and Epoxy. See "Wetted Material by Port Designation" chart below.				

Notes

- Proper operation requires an external capacitor placed as shown in Connection Diagram. Output is ratiometric to supply voltage variations of less than 10%. The maximum deviation from a best fit straight line (BFSL) fitted to the output measured over the pressure range at 25°C. Includes all errors due to pressure non linearity, hysteresis, and non repeatability.
- Total error band includes all accuracy errors, thermal errors over the compensated temperature range, and span and offset calibration tolerances. For ideal sensor output with respect to input pressure, reference Pressure Transfer Function charts below. TEB values are valid only at the calibrated supply voltage.
- For errors beyond the compensated temperature range, see Extended Temperature Multiplier chart below.
- Long term stability over a one year period with constant voltage and temperature
- Device Marking : Each device is marked complete with model number ,lot number and serial number (LLLL SSSS), and date code(YYWW)
- This product can be configured for custom OEM requirements, contact factory for higher accuracy range or for lower power consumption.

SUGGESTED PCB LAND PATTERN

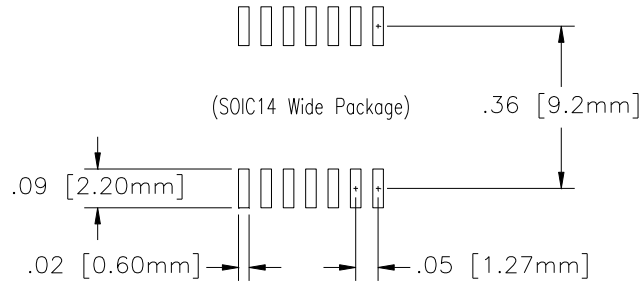

Notes

1. Place 100nF capacitor between Supply and GND to within 2 cm of sensor.

PRESSURE AND TEMPERATURE TRANSFER FUNCTION

Gage, Differential and Compound Pressure Types

Pressure Transfer Functions, Supply=5V

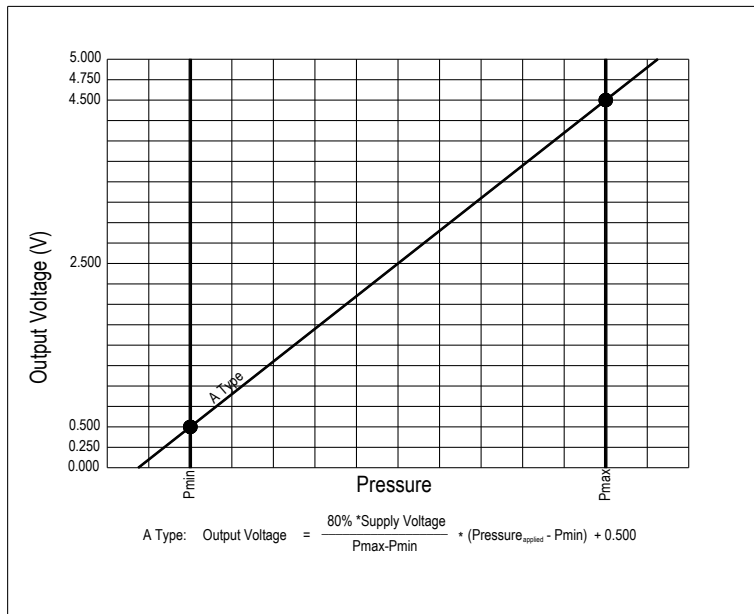

Sensor Output at Significant Percentages (Supply=5.000V)

% Output	Output Type A (PSI)	Voltage (V)
0	$P_{\text{min}} - (P_{\text{max}} - P_{\text{min}}) \cdot 10/80$	0.000
5		0.250
10	P_{min}	0.500
50		2.500
90	P_{max}	4.500
95		4.750
100	$P_{\text{max}} + (P_{\text{max}} - P_{\text{min}}) \cdot 10/80$	5.000

EXTENDED TEMPERATURE MULTIPLIER CHART

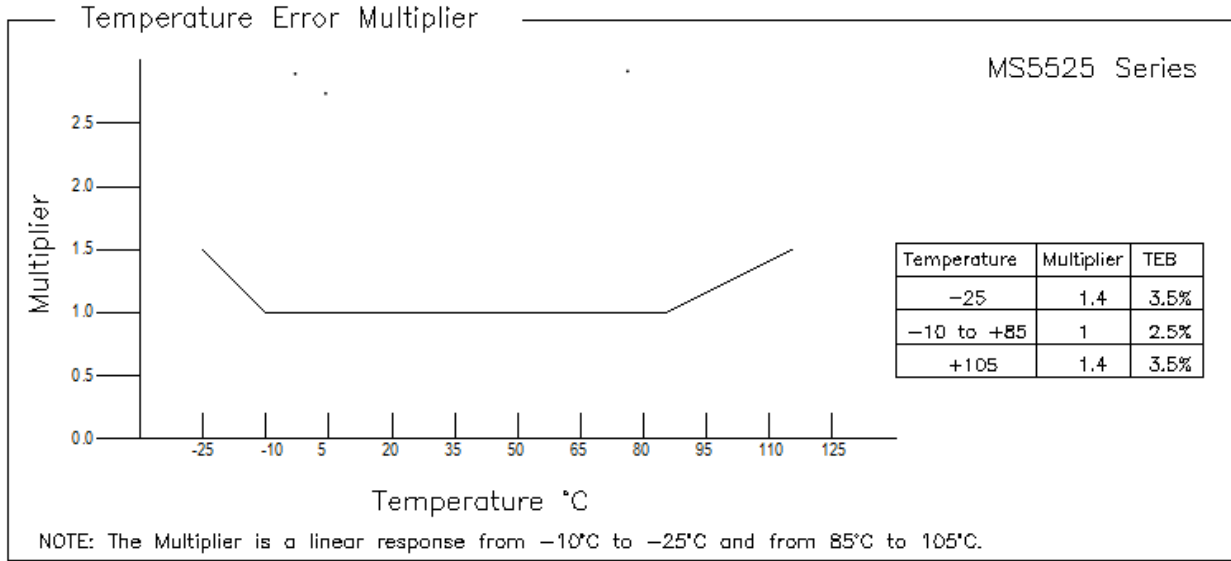

PACKAGE, PINOUT & PRESSURE TYPE CONFIGURATION

Model MS5525ASO-DBxxxS

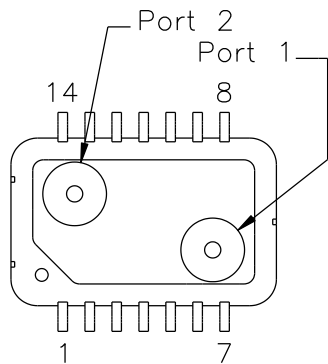

Model MS5525ASO-SBxxxS

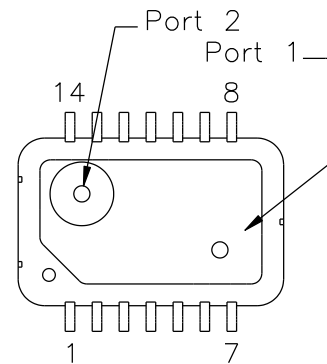

Model MS5525ASO-STxxxS

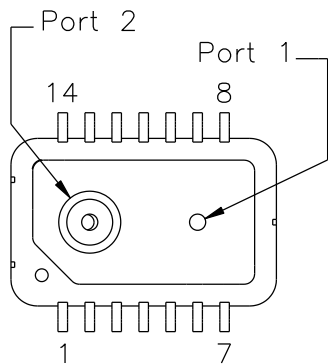

Model MS5525ASO-MMxxxS

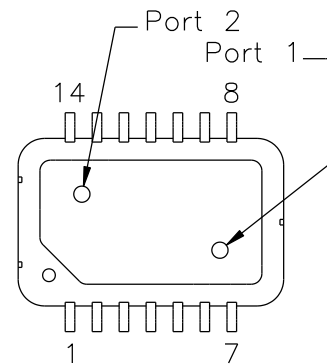

MS5525ASO

(Analog Small Outline)

Pin Name	Pin	Function
GND	1	Ground
SOUT-	2	mV Signal Output Negative
N/A	3	No Connection
N/A	4	No Connection
SOUT-	5	mV Signal Output Negative
GND	6	Ground
N/A	7	No Connection
VOUT	8	Analog Output
VDD	9	Positive Supply Voltage
N/A	10	No Connection
SOUT+	11	mV Signal Output Positive
N/A	12	No Connection
VDD	13	Positive Supply Voltage
SOUT+	14	mV Signal Output Positive

Notes:

Function pins that share the same name (SOUT+, SOUT-, VDD, GND) must be connected together on PCB for proper operation.

Pressure Type	Pmin	Pmax	Description
Absolute	0psiA	+Prange	Output is proportional to the difference between 0psiA (Pmin) and pressure applied to Port 2.
Differential/ Bidirectional	-Prange	+Prange	Output is proportional to the difference between Port 1 and Port 2. Output swings positive when Port 2 > Port 1. Output is 50% of supply voltage when Port 1 = Port 2.
Gauge	0psiG	+Prange	Output is proportional to the difference between 0psiG (Pmin) and Port 1. Output swings positive when Port 2 > Port 1.
Compound	-15psiG	+Prange	Output is proportional to the difference between -15psiG pressure (Pmin) and pressure applied to Port 2.

Prange is equal to the maximum full scale pressure specified in the ordering information.

WETTED MATERIAL BY PORT DESIGNATION

Style	Port	LCP	EPOXY RESIN	CuFe	SILICON	BOROSILICATE GLASS	RTV	GOLD
DB, DH	Port 1	X	X	X	X	X	X	X
	Port 2	X	X		X	X	X	
ST, SB	Port 1	X	X		X	X	X	

"X" Indicates Wetted Material

DIMENSIONS

DIMENSIONS ARE IN INCHES [mm]
Model MS5525ASO-DBxxxxS

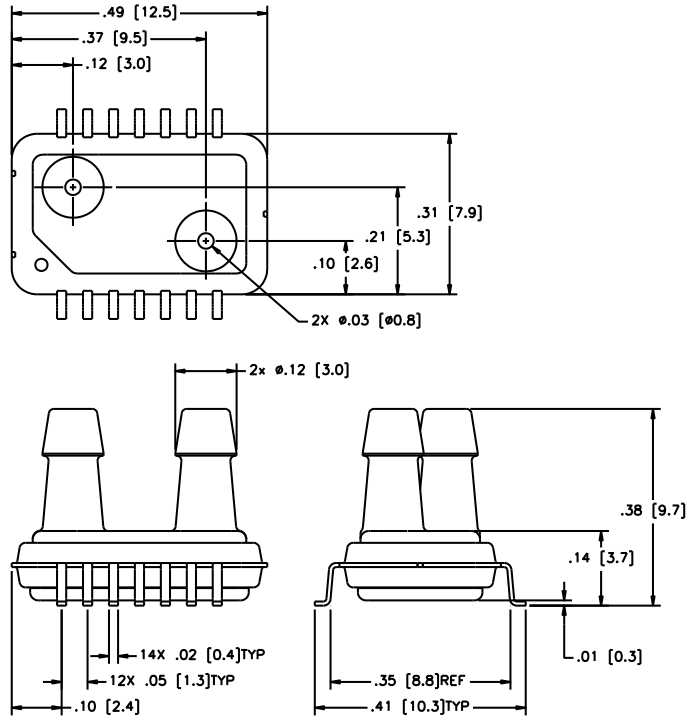

Model MS5525ASO-SBxxxxS

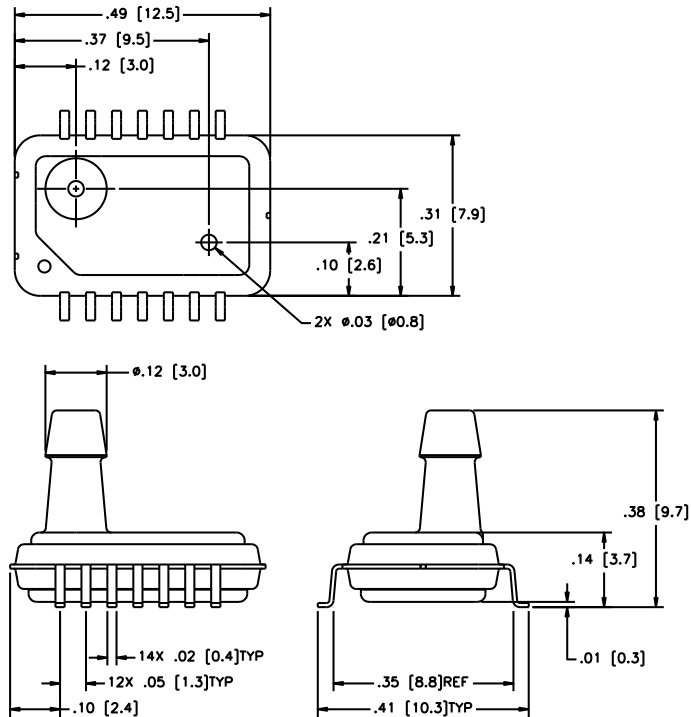

MS5525ASO
(Analog Small Outline)

DIMENSIONS ARE IN INCHES [mm]
Model MS5525ASO-STxxxxS

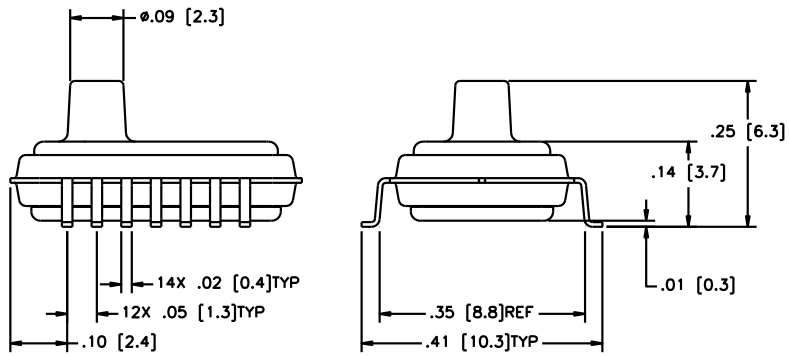
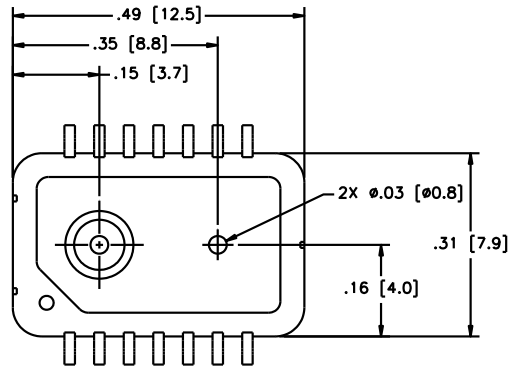

Model MS5525ASO-MMxxxxS

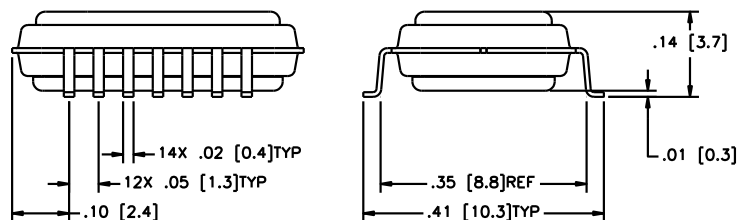
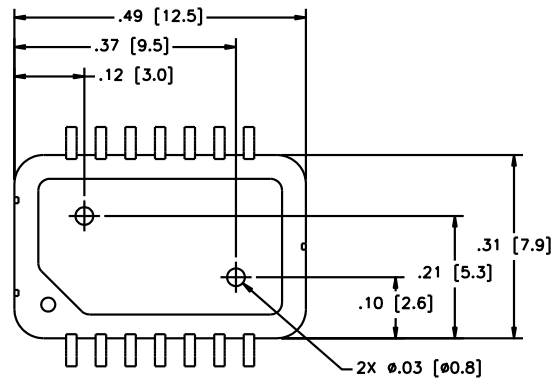

ORDERING INFORMATION

5525ASO	-	DB	5	A	002	G	P
Model	-	Package Style	Supply Voltage	Output Type	Pressure Range (psi)	Pressure Type	Pin Style
MS5525ASO	-	DB = Dual Barb SB = Single Barb ST = Single Tube DH = Dual Hole	5 = 5.0 Vdc	A = 10% to 90%	*001 *002 *005 015 **030	A = Absolute D = Differential G = Gage C = Compound	S = Gull Wing

Notes: * = Differential and Gage only
** = Absolute and Gage only

NORTH AMERICA

Measurement Specialties, Inc.,
a TE Connectivity Company
45738 Northport Loop West
Fremont, CA 94538
Tel: 1-800-767-1888
Fax: 1-510-498-1578
Sales: pfg.cs.amer@meas-spec.com

EUROPE

Measurement Specialties (Europe), Ltd.,
a TE Connectivity Company
26 Rue des Dames
78340 Les Clayes-sous-Bois, France
Tel: +33 (0) 130 79 33 00
Fax: +33 (0) 134 81 03 59
Sales: pfg.cs.emea@meas-spec.com

ASIA

Measurement Specialties (China), Ltd.,
a TE Connectivity Company
No. 26 Langshan Road
Shenzhen High-Tech Park (North)
Nanshan District, Shenzhen 518057
China
Tel: +86 755 3330 5088
Fax: +86 755 3330 5099
Sales: pfg.cs.asia@meas-spec.com

TE.com/sensorsolutions

Measurement Specialties, Inc., a TE Connectivity company.

Measurement Specialties, TE Connectivity, TE Connectivity (logo) and EVERY CONNECTION COUNTS are trademarks. All other logos, products and/or company names referred to herein might be trademarks of their respective owners.

The information given herein, including drawings, illustrations and schematics which are intended for illustration purposes only, is believed to be reliable. However, TE Connectivity makes no warranties as to its accuracy or completeness and disclaims any liability in connection with its use. TE Connectivity's obligations shall only be as set forth in TE Connectivity's Standard Terms and Conditions of Sale for this product and in no case will TE Connectivity be liable for any incidental, indirect or consequential damages arising out of the sale, resale, use or misuse of the product. Users of TE Connectivity products should make their own evaluation to determine the suitability of each such product for the specific application.

© 2015 TE Connectivity Ltd. family of companies All Rights Reserved.