



XLT OCS Model: HE-XT105 / HEXT240C115 / HEXT240C015

12 Digital DC Inputs / 12 Digital DC Outputs
2 Analog Inputs (High Resolution) / 2 Analog Outputs

1 Specifications

Digital DC Inputs			Digital DC Outputs		
Inputs per Module	12 including 4 configurable HSC inputs		Outputs per Module	12 including 2 configurable PWM outputs	
Commons per Module	1		Commons per Module	1	
Input Voltage Range	12 VDC / 24 VDC		Output Type	Sourcing / 10 K Pull-Down	
Absolute Max. Voltage	35 VDC Max.		Absolute Max. Voltage	28 VDC Max.	
Input Impedance	10 kΩ		Output Protection	Short Circuit	
Input Current	Positive Logic	Negative Logic	Max. Output Current per point	0.5 A	
Upper Threshold	0.8 mA	-1.6 mA	Max. Total Current	4 A Continuous	
Lower Threshold	0.3 mA	-2.1 mA	Max. Output Supply Voltage	30 VDC	
Max Upper Threshold	8 VDC		Minimum Output Supply Voltage	10 VDC	
Min Lower Threshold	3 VDC		Max. Voltage Drop at Rated Current	0.25 VDC	
OFF to ON Response	1 ms		Max. Inrush Current	650 mA per channel	
ON to OFF Response	1 ms		Min. Load	None	
HSC Max. Switching Rate	10 kHz Totalizer/Pulse, Edges 5 kHz Frequency/Pulse, Width 2.5 kHz Quadrature		OFF to ON Response	1 ms	
			ON to OFF Response	1 ms	
			Output Characteristics	Current Sourcing (Positive Logic)	
Analog Inputs, High Resolution					
Number of Channels	2		Thermocouple	Temperature Range	
Input Ranges (Selectable)	0 - 10 VDC 0 - 20 mA 4 - 20 mA 100mV PT100 RTD, and J, K, N, T, E, R, S, B Thermocouples		B / R / S	2912°F to 32.0°F (1600°C to 0°C)	
			E	1652°F to -328°F (900°C to -200°C)	
			T	752.0°F to -400.0°F (400°C to -240°C)	
Safe input voltage range	10 VDC: -0.5 V to +15 V 20 mA: -0.5 V to +6 V RTD / T/C: ±24 VDC		J	1382.0°F to -346.0°F (750°C to -210°C)	
			K / N	2498.0°F to -400°F (1370°C to -240°C)	
Nominal Resolution	10V, 20mA, 100mV: 14 Bits RTD, Thermocouple: 16 Bits		Thermocouple Common Mode Range	±10V	
Input Impedance (Clamped @ -0.5 VDC to 12 VDC)	Current Mode: 100 Ω, 35mA Max. Continuous Voltage Mode: 500 kΩ, 35mA Max. Continuous		Converter Type	Delta Sigma	
			Max. Error at 25°C (*excluding zero)	*4-20 mA ±0.10%* *0-20 mA ±0.10%* *0-10 VDC ±0.10%* RTD (PT100) ±1.0 °C 0-100 mV ±0.05%	
%AI full scale	10 V, 20 mA, 100 mV: 32,000 counts full scale. RTD / T/C: 20 counts / °C		Max Thermocouple Error (After Warm Up Time of One Hour)	±0.2% (±0.3% below -100°C)	
Max. Over-Current	35 mA		Conversion Speed, Both Channels Converted	10V, 20mA, 100mV: 30 Times/Second RTD, Thermocouple: 7.5 Times/Second	
Open Thermocouple Detect Current	50 nA		Conversion Time per Channel	10V, 20mA, 100mV: 16.7mS RTD, Thermocouple: 66.7mS	
Analog Outputs	2		RTD Excitation Current	250 μA	
			General Specifications		
Number of Channels	2		Required Power (SS) -22 Steady State Power	130 mA @ 24 VDC 390mA with heater operating	
Output Ranges	0-10 VDC, 0-20 mA		Required Power (Inrush)	30 A for 1 ms @ 24 VDC	
Nominal Resolution	12 Bits		Primary Power Range	10 - 30 VDC	
Update rate	Once per PLC scan		Operating Temperature	-10° to 60° Celsius -22 Heater Option -40 to 60 ° Celsius	
Minimum 10 V load	1 kΩ		Storage Temperature	14 to 140°F (-10 to 60°C)	
Maximum 20 mA load	500 Ω		Relative Humidity	5 to 95% Non-condensing	
Analog Outputs; Output Points Required	2		Filtering	15Hz hash (noise) filter 1-128 scan digital running average filter	
Maximum Error at 25°C (excluding zero)	0.1%		Terminal Type	Screw Type, 5 mm Removable	
			Weight	12.5 oz. (354.36)	
Additional error for temperatures other than 25°C	0.01% / °C		CE	See Compliance Table at http://www.heapg.com/Pages/TechSupport/ProductCert.html	
			UL		
			Clock Accuracy	+/- Seven Minutes/Month at 20C	

Note: Highest usable frequency for PWM output is 65 KHz

2 Panel Cut-Out and Dimensions

Note: Max. panel thickness: 5 mm.

Refer to XLe/XLt User Manual for panel box information and a handy checklist of requirements.

Note:
The tolerance to meet NEMA standards is ± 0.005" (0.1 mm).

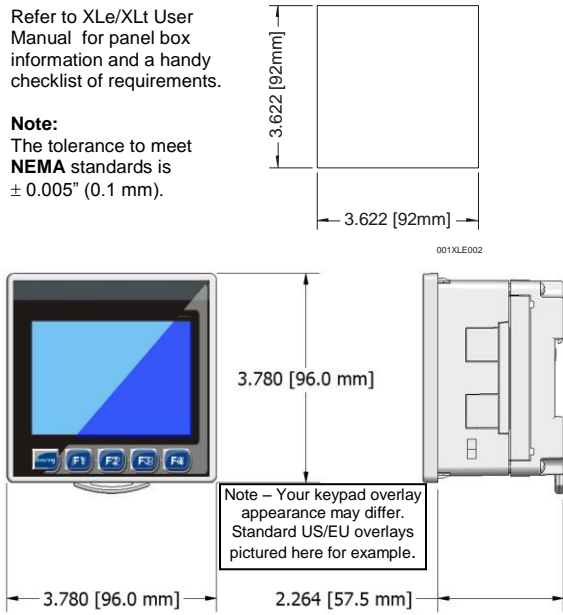

3 Ports / Connectors / Cables

Note: The case of the XLt is black, but for clarity, it is shown in a lighter gray color.

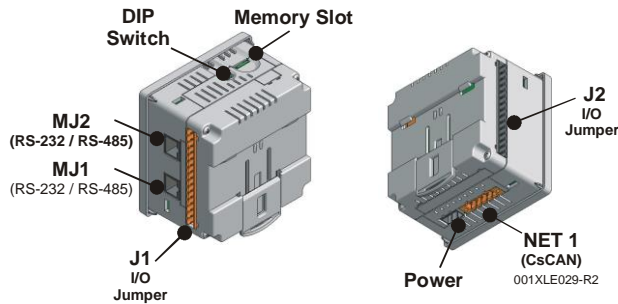

Memory Slot:
Uses Removable Memory for data logging, screen captures, program loading and recipes.
Horner Part No.: HE-MC1

Serial Communications:
MJ1: (RS-232 / RS-485) Use for Cscape programming and Application-Defined Communications.

MJ2: (RS-232 / RS-485) Use for Application-Defined Communications.

To Remove Back Cover:
Unscrew 4 screws located on the back of the unit.
Remove Cover.

CAUTION:
Do not over tighten screws when replacing the back cover.

I/O Jumpers (Not Shown): I/O Jumpers (JP) are located internally. To access, remove back cover of unit.

Wiring Connectors (J1 – J3), I/O Jumpers (JP1 – JP4), and External Jumpers (RS-485) are described in the **Wiring and Jumpers** section of this document.

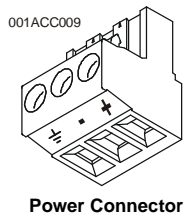

Power Connector

Power Up:
Connect to Earth Ground.
Apply 10 - 30 VDC.
Screen lights up.

Torque rating 4.5 – 7 Lb-In (0.50 – 0.78 N-m)

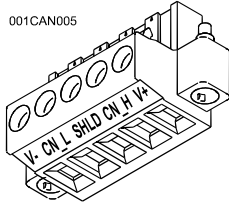

CAN Connector

Use the CAN Connector when using CsCAN network.

Torque Rating 4.5 – 7 Lb-In (0.50 – 0.78 N-m)

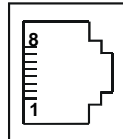

Serial Communications:
MJ1 and MJ2 (RS-232 / RS-485)

Pin	MJ1 Pins		MJ2 Pins	
	Signal	Direction	Signal	Direction
8	TXD	OUT	TXD	OUT
7	RXD	IN	RXD	IN
6	0 V	Ground	0 V	Ground
5*	+5 60mA	OUT	+5 60mA	OUT
4	RTS	OUT	TX-	OUT
3	CTS	IN	TX+	OUT
2	RX- / TX-	IN / OUT	TX-/RX-	IN
1	RX+ / TX+	IN / OUT	TX+/RX+	IN

* +5Vdc 60mA Max

4 Wiring and Jumpers

• Wire according to the type of inputs / outputs used and select the appropriate jumper option. Use Copper Conductors in Field Wiring Only, 60/75° C

Wiring Specifications

• For I/O wiring (discrete), use the following wire type or equivalent: Belden 9918, 18 AWG (0.8 mm²) or larger.

• For shielded Analog I/O wiring, use the following wire type or equivalent: Belden 8441, 18 AWG (0.8 mm²) or larger.

• For CAN wiring, use the following wire type or equivalent: Belden 3084, 24 AWG (0.2 mm²) or larger.

Location of I/O jumpers (JP) and wiring connectors (J1 – J3).

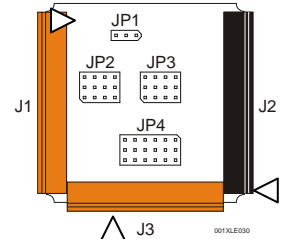

Positive Logic vs. Negative Logic Wiring
The XLe can be wired for Positive Logic inputs or Negative Logic inputs.

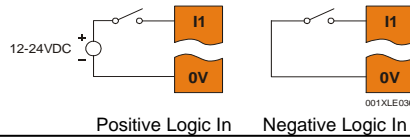

4.1 I/O Jumpers Settings (JP1 – JP4)

Note: The Cscape Module Setup configuration must match the selected I/O (JP) jumper settings.

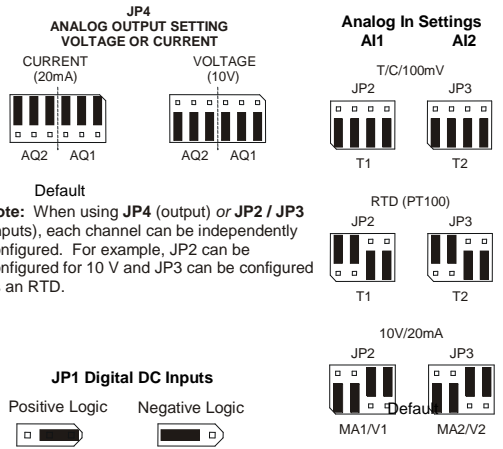

4.2 External DIP Switch Settings (or Jumpers Settings)

The External DIP Switches are used for termination of the RS-485 ports. The XLt is shipped un-terminated.

As seen when looking at the top of the XLt unit: Refer to Section 3 for the location of the External Jumpers.

To terminate, select one of the jumpers shipped with the product and insert it based upon the option that is desired or, select the switch and configure based upon the option that is desired.

DIPSW3: FACTORY USE ONLY (tiny bootloader firmware downloading). NOT TO BE USED FOR NORMAL OCS OPERATION.
 DIPSW2: MJ2 Termination (default – none)
 DIPSW1: MJ1 Termination (default – none)

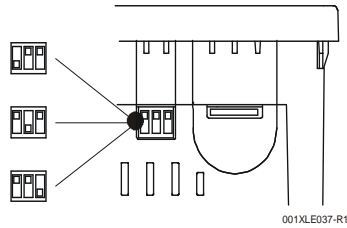

4.3 Wiring Examples

Note: The wiring examples show Positive Logic input wiring.

J1 Orange	Name
I1	IN1
I2	IN2
I3	IN3
I4	IN4
I5	IN5
I6	IN6
I7	IN7
I8	IN8
H1	HSC1 / IN9
H2	HSC2 / IN10
H3	HSC3 / IN11
H4	HSC4 / IN12
NC	No Connect
NC	No Connect
0V	Ground

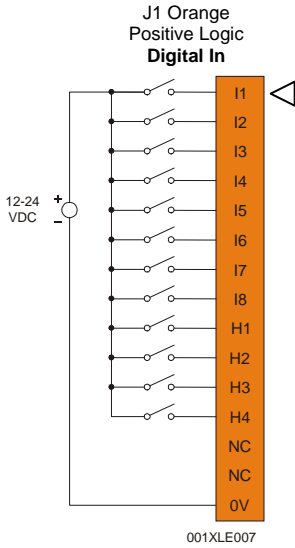

J2 Black	Name
0V	Ground
V+*	V+*
NC	No Connect
Q12	OUT12
Q11	OUT11
Q10	OUT10
Q9	OUT9
Q8	OUT8
Q7	OUT7
Q6	OUT6
Q5	OUT5
Q4	OUT4
Q3	OUT3
Q2	OUT2 / PWM2
Q1	OUT1 / PWM1

V+* Supply for Sourcing Outputs

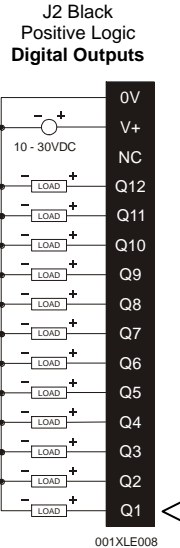

J3 Orange	Name
T1+	T/C / RTD IN1+ / 100 mV+
T1-	T/C / RTD IN1- / 100 mV-
T2+	T/C / RTD IN2+ / 100 mV+
T2-	T/C / RTD IN2- / 100 mV-
AQ1	10 V / 20 mA OUT1
AQ2	0 V / 20 mA OUT2
0V	Ground
MA1	20 mA IN1
V1	10 V IN1
0V	Ground
MA2	20 mA IN2
V2	10 V IN2
0V	Ground

J3 Orange Analog In / Analog Out
 Note: A total of 2 Analog Inputs can be used (T/C, RTD, mV, mA, and V).

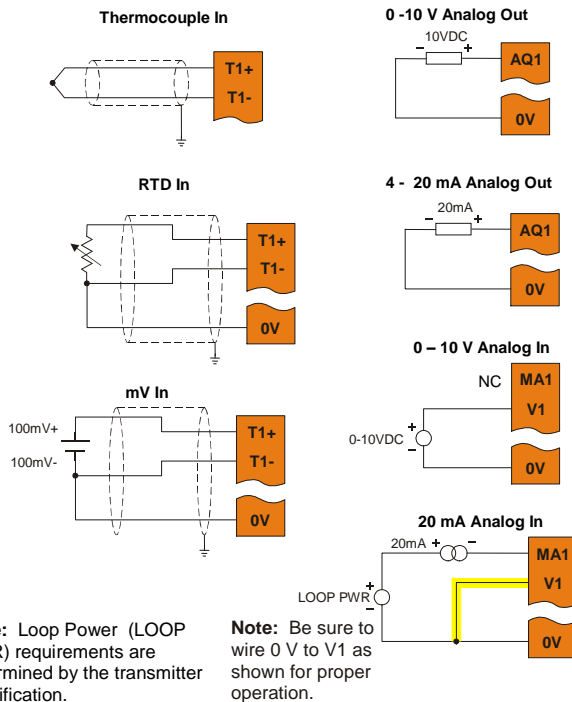

Note: Loop Power (LOOP PWR) requirements are determined by the transmitter specification.

Note: Be sure to wire 0 V to V1 as shown for proper operation.

5 I/O Register Map

Registers	Description
%I1 to %I24	Digital Inputs
%I32	Output Fault
%I25 to %I31	Reserved
%Q1 to %Q16	Digital outputs
%Q17	Clear HSC1 accumulator to 0
%Q18	Totalizer: Clear HSC2 Quadrature 1-2: Accumulator 1 Reset to max – 1
%Q19	Clear HSC3 Accumulator to 0
%Q20	Totalizer: Clear HSC4 Quadrature 3-4: Accumulator 3 Reset to max – 1
%Q21 to %Q32	Reserved
%AI1 to %AI4	Analog inputs
%AI5, %AI6	HSC1 Accumulator
%AI7, %AI8	HSC2 Accumulator
%AI9, %AI10	HSC3 Accumulator
%AI11, %AI12	HSC4 Accumulator
%AQ1, %AQ2	PWM1 Duty Cycle
%AQ3, %AQ4	PWM2 Duty Cycle
%AQ5, %AQ6	PWM Prescale
%AQ7, %AQ8	PWM Period
%AQ9 to %AQ14	Analog outputs

Note: Not all XLe units contain the I/O listed in this table.

Registers	PWM	HSC	Stepper
%AQ1	PWM1 Duty Cycle (32 bit)	HSC1 Preset Value	Start Frequency
%AQ2			Run Frequency
%AQ3	PWM2 Duty Cycle (32 bit)	HSC2 Preset Value	Accel Count (32 bit)
%AQ4			
%AQ5	PWM Prescale		Run Count (32 bit)
%AQ6			
%AQ7	PWM Period (32 bit)		Decel Count (32 bit)
%AQ8			
%Q1			Run
%I30			Ready/Done
%I31			Error

6 MJ2 Pinouts in Full and Half Duplex Modes

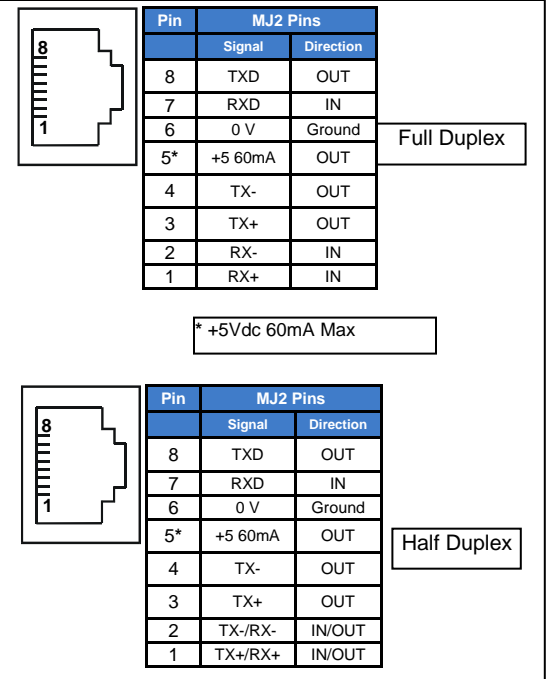

7 Digital Filtering for Analog Inputs

The digital filter is updated once per conversion. It is an "IIR" running average filter that emulates a simple RC filter. The equivalent time constant is determined by the Filter Constant and the sum of the conversion times for the two channels. The Filter two input mode selections. This filter delay is in addition to the PLC scan delay. Constant determines the weight given to the most recent conversion. The following table lists the equivalent time constant for the three possible total conversion times, which are dependent upon the

Equivalent RC Time Constant in Seconds (Nominal time to reach 63% of final value.)			
Filter Constant	Total Conversion Time in Seconds		
		0.03	0.09
0*	0.03*	0.09*	0.13*
1	0.07	0.18	0.27
2	0.13	0.35	0.53
3	0.27	0.71	1.07
4	0.53	1.41	2.13
5	1.07	2.83	4.27
6	2.14	5.65	8.54
7	4.28	11.30	17.08

* No filter delay, reading is unfiltered conversion value

8 Thermocouple Grounding Schemes

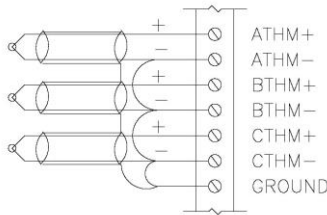

Ungrounded Thermocouples

Alternate Shield Connection for Ungrounded Thermocouples.

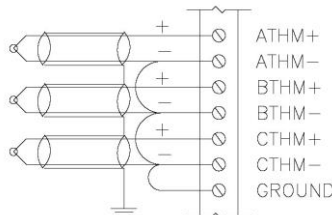

Ungrounded Thermocouples

Preferred Shield Connection for Ungrounded Thermocouples.

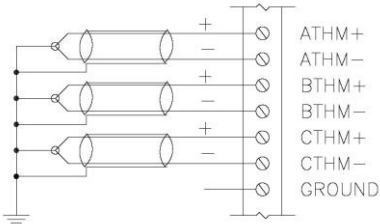

Grounded Thermocouples

Field Ground Potential Less Than Seven Volts AC

Typical Shield Connection for Grounded Thermocouples

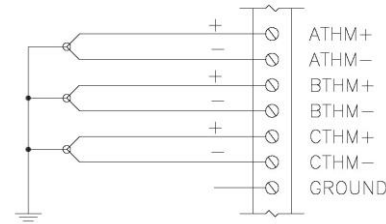

Grounded Thermocouples

Field Ground Potential Less Than Seven Volts AC

Shields Connected at One End Only May be Used to Reduce Noise

Grounded Thermocouples May Use the Ungrounded Thermocouple Shield Connections if the Shield is not Grounded at the Field End

Note: The examples for thermocouple grounding schemes above are generic illustrations. The XT105 has two thermocouple inputs.

10 Technical Support

For assistance and manual updates, contact Technical Support at the following locations:

North America:

(317) 916-4274

www.heapg.com

email: techsppt@heapg.com

Europe:

(+) 353-21-4321-266

www.horner-apg.com

email: techsupport@hornerir.ie

9 Safety

When found on the product, the following symbols specify:

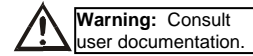
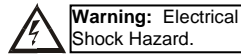

This equipment is suitable for use in Class I, Division 2, Groups A, B, C and D or Non-hazardous locations only

WARNING – EXPLOSION HAZARD – Substitution of components may impair suitability for Class I, Division 2
AVERTISSEMENT - RISQUE D'EXPLOSION - LA SUBSTITUTION DE COMPOSANTS PEUT RENDRE CE MATERIA INACCEPTABLE POUR LES EMLACEMENTS DE CLASSE 1, DIVISION 2

WARNING – EXPLOSION HAZARD – Do not disconnect equipment unless power has been switched off or the area is known to be non-hazardous.
AVERTISSEMENT - RISQUE D'EXPLOSION - AVANT DE DECONNECTOR L'EQUIPMENT, COUPER LE COURANT OU S'ASSURER QUE L'EMPLACEMENT EST DESIGNE NON DANGEREUX.

WARNING: To avoid the risk of electric shock or burns, always connect the safety (or earth) ground before making any other connections.

WARNING: To reduce the risk of fire, electrical shock, or physical injury it is strongly recommended to fuse the voltage measurement inputs. Be sure to locate fuses as close to the source as possible.

WARNING: Replace fuse with the same type and rating to provide protection against risk of fire and shock hazards.

WARNING: In the event of repeated failure, do not replace the fuse again as a repeated failure indicates a defective condition that will not clear by replacing the fuse.

WARNING: Only qualified electrical personnel familiar with the construction and operation of this equipment and the hazards involved should install, adjust, operate, or service this equipment. Read and understand this manual and other applicable manuals in their entirety before proceeding. Failure to observe this precaution could result in severe bodily injury or loss of life.

This device complies with part 15 of the FCC Rules. Operation is subject to the following two conditions:

1. This device may not cause harmful interference.
2. This device must accept any interference received, including interference that may cause undesired operation.

- All applicable codes and standards need to be followed in the installation of this product.
- Adhere to the following safety precautions whenever any type of connection is made to the module:
 - Connect the safety (earth) ground on the power connector first before making any other connections.
 - When connecting to electric circuits or pulse-initiating equipment, open their related breakers.
 - Do not make connections to live power lines.
 - Make connections to the module first; then connect to the circuit to be monitored.
 - Route power wires in a safe manner in accordance with good practice and local codes.
 - Wear proper personal protective equipment including safety glasses and insulated gloves when making connections to power circuits.
 - Ensure hands, shoes, and floor are dry before making any connection to a power line.
 - Make sure the unit is turned OFF before making connection to terminals.
 - Make sure all circuits are de-energized before making connections.
 - Before each use, inspect all cables for breaks or cracks in the insulation. Replace immediately if defective.
- Use Copper Conductors in Field Wiring Only, 60/75° C

No part of this publication may be reproduced without the prior agreement and written permission of Horner APG, Inc. Information in this document is subject to change without notice.