

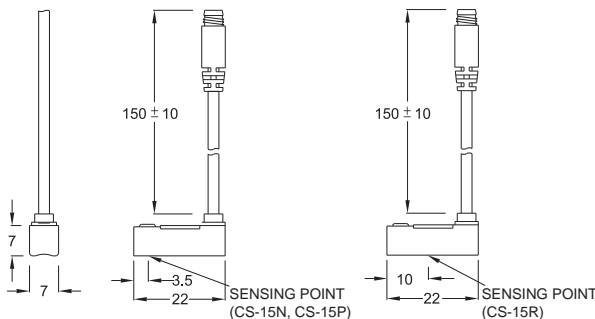

### ■ DIMENSIONS

CS-15R, CS-15N, CS-15P /  
 CS-15R-QD, CS-15N-QD, CS-15P-QD



### ■ QD PINOUT

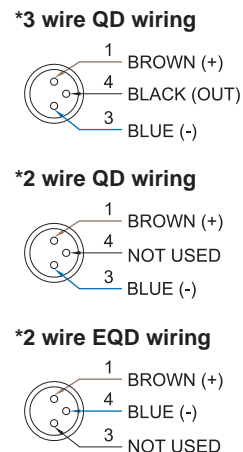

### ■ SPECIFICATIONS

Unit:mm

TYPE	CS-15R	CS-15N	CS-15P
<b>CONNECT DIAGRAM</b>			
<b>CHARACTERISTICS</b>			
Wiring Method	2-Wire Type	3-Wire Type	
Switching Logic	SPST, Normally Open	Solid State Output, Normally Open	
Sensor Type	Reed Switch	NPN Current Sinking	PNP Current Sourcing
Operating Voltage	5~240V DC/AC	5~30V DC	
Switching Current	100mA max.	200mA max.	
Contact Rating (*1)	10W max.	6W max.	
Current Consumption	-	20mA @ 24V DC max.	
Voltage Drop	3.5V max.	0.5 V max.	
Leakage Current	-	0.01 mA max.	
Indicator	Red LED		Green LED
Cable	ø2.8, 2C, PVC	ø2.8, 3C, PVC	
Operating Frequency	200 Hz	1000 Hz	
Magnet Requirement (*2)	50Gauss	40Gauss	
Temperature Range	-10~70°C (+14~158°F)		
Shock (*3)	30G	50G	
Vibration (*4)	9G		
Enclosure Classification	IEC 60529 IP67 (NEMA 6)		
Protection Circuit (*5)	1	3,4	

**NOTE:**

1. WARNING: Never exceed rating (Watt=Voltage x Amperage). Permanent damage to sensor will occur.
2. Measuring standard target: ø15.5xø8X5t (Anisotropy rubber magnet)
3. Sin wave / X, Y, Z 3 directions / 3 times each direction / 11 ms each time.
4. Double amplitude 1.5 mm / 10Hz~55Hz~10Hz (Sweep 1 min) / X, Y, Z 3 directions / 1 hour each time.
5. 1=None / 2=Short-circuit / 3=Power Source Reverse polarity / 4=Surge Suppression

### ■ MOUNTING CLAMPS

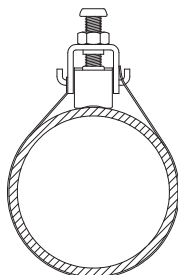

BK Series  
 (See Page 2-43)

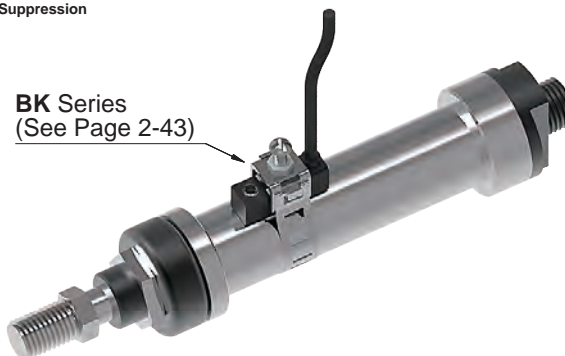

Unit:mm