

MODEL EGAXT3 ACCELEROMETER

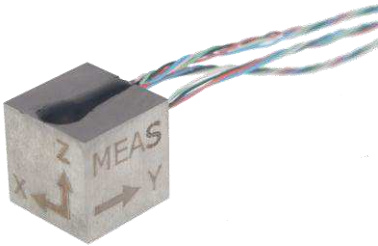

SPECIFICATIONS

- Miniature Triaxial Design
- DC Response, Critically Damped
- 10,000 g Over-range Stops
- Broad Temperature Range

The **Model EGAXT3** miniature triaxial accelerometer combines a damping ratio of 0.7 (Nominal) with built-in over-range stops that are set to protect the unit against 10,000g shocks. This is ideal for applications which may experience rough handling or in situations where the accelerometer must survive a high initial overload in order to make a low g measurement.

FEATURES

- Miniature Triaxial, Low Weight
- Static and Dynamic Measurement
- Frequency Response through 3000 Hz
- $\pm 1\%$ Non-Linearity
- -40°C to $+120^{\circ}\text{C}$ Operating Range
- 10,000g Over-range Protection

APPLICATIONS

- Flight Test & Control
- Launch Vehicles
- Robotics
- Shock Testing

MODEL EGAXT3 ACCELEROMETER

DIMENSIONS

EGAXT3-F Dimensions

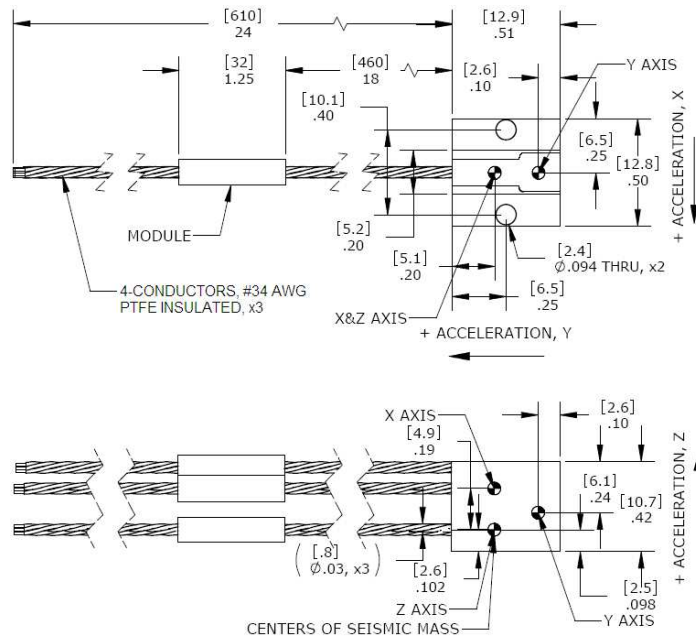

EGAXT Dimensions

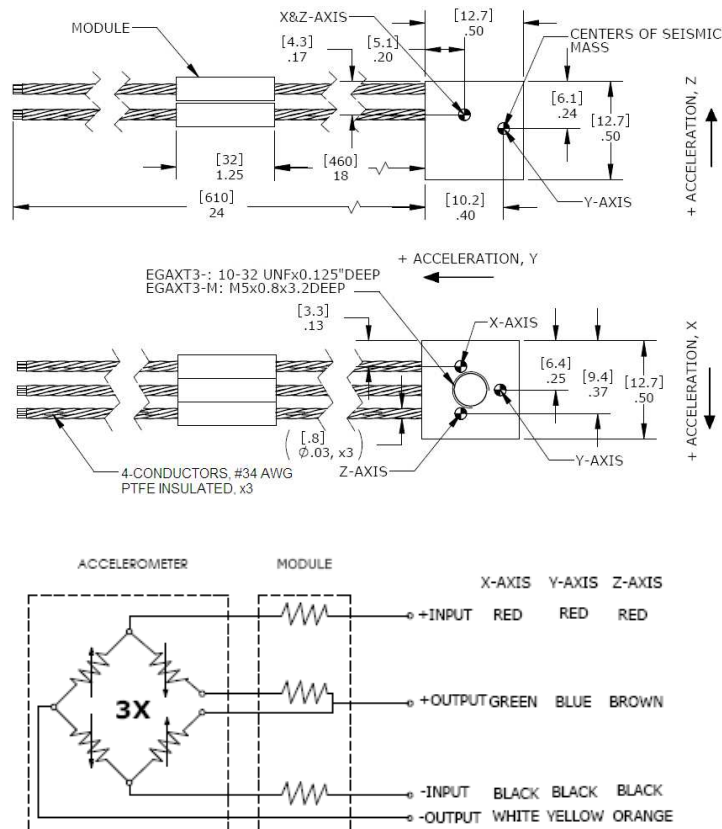

MODEL EGAXT3 ACCELEROMETER

PERFORMANCE SPECIFICATIONS

All values are typical at +24°C, 100Hz and 15Vdc excitation unless otherwise stated. Measurement Specialties reserves the right to update and change these specifications without notice. Standard product parameters are described in PSC-1004 for Plug & Play DC Accelerometers.

Parameters										Notes
DYNAMIC										
Range (g)	±5	±10	±25	±50	±100	±250	±500	±1000	±2500	
Sensitivity (mV/g) ¹	5.2-11.3	4.2-9.0	2.1-4.5	1.57-3.38	1.05-2.25	.52-1.13	.35-.75	.17-.38	.07-.15	
Frequency Response min. (Hz)	0-120	0-140	0-300	0-350	0-400	0-500	0-750	0-1000	0-1400	±½ dB
Frequency Response nom. (Hz)	0-250	0-300	0-600	0-700	0-900	0-1000	0-1500	0-2000	0-3000	±½ dB
Natural Frequency (Hz)	500	600	1200	1400	1700	2000	3000	4000	6000	
Non-Linearity (%FSO)	±1	±1	±1	±1	±1	±1	±1	±1	±1	
Transverse Sensitivity (%)	<3	<3	<3	<3	<3	<3	<3	<3	<3	
Damping Ratio	0.7	0.7	0.7	0.7	0.7	0.7	0.7	0.7	0.7	Nominal
Shock Limit (g)	2000	2000	5000	5000	10000	10000	10000	10000	10000	
ELECTRICAL										
Zero Acceleration Output (mV)	±15									Differential
Excitation Voltage (Vdc)	15 (can be used from 2 to 15Vdc but lower excitation voltage will decrease sensitivity accordingly)									
Input Resistance (Ω)	2000									Nominal
Output Resistance (Ω)	1000									Nominal
Insulation Resistance (MΩ)	>100									@50Vdc
Ground Isolation	Isolated from Mounting Surface									
ENVIRONMENTAL										
Thermal Zero Shift	±2.5mV / 50°C (±2.5mV / 100°F)									
Thermal Sensitivity Shift	+1% to -4% / 50°C (+1% to -4% / 100°F)									
Operating Temperature	-40 to 120°C (-40 to 250°F)									
Compensated Temperature	20 to 80°C (70 to 170°F), contact factory for other temperature compensation options									
Storage Temperature	-40 to 120°C (-40 to 250°F)									
Humidity	Epoxy Sealed, IP61									
PHYSICAL										
Case Material	Stainless Steel									
Cable	4x #34 AWG PTFE Leads, 24 inch, each axis									
Weight	<6 grams									
Mounting	Adhesive or Screw Mount Versions Available (-F configuration)									

¹ Output is ratiometric to excitation voltage

Calibration supplied: CS-FREQ-0100 NIST Traceable Amplitude Calibration from 20Hz to ±1/2dB Frequency Response Limit

Optional accessories: 101 Three Channel DC Signal Conditioner Amplifier
140 Auto-zero Inline Amplifier

The information in this sheet has been carefully reviewed and is believed to be accurate; however, no responsibility is assumed for inaccuracies. Furthermore, this information does not convey to the purchaser of such devices any license under the patent rights to the manufacturer. Measurement Specialties, Inc. reserves the right to make changes without further notice to any product herein. Measurement Specialties, Inc. makes no warranty, representation or guarantee regarding the suitability of its product for any particular purpose, nor does Measurement Specialties, Inc. assume any liability arising out of the application or use of any product or circuit and specifically disclaims any and all liability, including without limitation consequential or incidental damages. Typical parameters can and do vary in different applications. All operating parameters must be validated for each customer application by customer's technical experts. Measurement Specialties, Inc. does not convey any license under its patent rights nor the rights of others.

MODEL EGAXT3 ACCELEROMETER

ORDERING INFO

EGAXT3-F-100-Z1/L2M/C

I | I | | Options, otherwise leave blank

I | | Range (100 is 100g)

I | | Housing, F for flange mount

(otherwise leave blank)

Special Cable Length:

Connector Wired to Cable:

Compensated Temp Ranges:

Excitation Voltage:

L00F = Replace "00" with length in feet

L00M = Replace "00" with length in meter

C = Microtech type male or equivalent

Standard = +20 to +80°C (+70 to +170°F)

Z* = Non standard, contact factory

Standard = 15Vdc

V* = Non standard, contact factory

Example: EGAXT3-F-100-/L2M

Model EGAXT3, Flange Mount Housing, 100g Range, 2 Meter Cable Length

NORTH AMERICA

Measurement Specialties, Inc.,
a TE Connectivity Company
1000 Lucas Way
Hampton, VA 23666
Sales and Customer Service
Tel: +1-800-745-8008 or
+1-757-766-1500
Fax: +1-757-766-4297
t&m@meas-spec.com

EUROPE

MEAS France SAS
a TE Connectivity Company
26 Rue des Dames
F78340 Les Clayes-sous-Bois
France
Sales and Customer Service
Tel: +33 (0) 1 79 33 00
Fax: +33(0)1 34 81 03 59
t&m@meas-spec.com

ASIA

Measurement Specialties (China), Ltd.,
a TE Connectivity Company
No. 26 Langshan Road
Shenzhen High-Tech Park (North)
Nanshan District, Shenzhen 518057
China
Sales and Customer Service
Tel: +86 755 3330 5088
Fax: +86 755 3330 5099
t&m@meas-spec.com

TE.com/sensorsolutions

Measurement Specialties, Inc., a TE Connectivity company.

Measurement Specialties, TE Connectivity, TE Connectivity (logo) and EVERY CONNECTION COUNTS are trademarks. All other logos, products and/or company names referred to herein might be trademarks of their respective owners.

The information given herein, including drawings, illustrations and schematics which are intended for illustration purposes only, is believed to be reliable. However, TE Connectivity makes no warranties as to its accuracy or completeness and disclaims any liability in connection with its use. TE Connectivity's obligations shall only be as set forth in TE Connectivity's Standard Terms and Conditions of Sale for this product and in no case will TE Connectivity be liable for any incidental, indirect or consequential damages arising out of the sale, resale, use or misuse of the product. Users of TE Connectivity products should make their own evaluation to determine the suitability of each such product for the specific application.

© 2015 TE Connectivity Ltd. family of companies All Rights Reserved.