

FEATURES

- Static and dynamic applications
- Rod end available in option
- Integrated Amplifier optional
- IP65 and IP67 optional

APPLICATIONS

- Process control equipment
- Cable stress tests benches
- Shock absorbers tests benches
- Structure fatigue tests
- Laboratory and Research

FN3002

Load Cell Tension and Compression

SPECIFICATIONS

- Standard ranges 10kN to 2000kN or [2 klbf to 400 klbf]
- Harsh industrial environment
- Very high stability
- Stainless steel or aluminum
- High IP protection available
- High level output with integrated amplifier

The **FN3002** is suitable for measuring cable tension and for use in test benches and in many industrial applications. The **FN3002** with its compact dimensions and measures tension and compression in standard ranges from 10 kN to 2 000 kN [2 klbf to 400 klbf].

Numerous options are available for adaptation to severe environments, for example, **IP67** or **IP68** protection. A model with integrated amplifier for high-level output is also available.

With many years of experience as a designer and manufacturer of sensors, TE CONNECTIVITY often works with customers to design or customize sensors for specific uses and testing environments.

On request, Instruction documents can be provided to ease the selection and use of our sensors and provide helpful tips.

STANDARD RANGES

Ranges in N (FS)	10k	20k	50k	100k	200k	500k	1000k	2000k
Ranges in lbf	2k	4k	10k	20k	40k	100k	200k	400k
Stiffness in N/m	6x10 ⁷	1x10 ⁸	3x10 ⁸	7x10 ⁸	8.5x10 ⁸	1.5x10 ⁹	2x10 ⁹	3.5x10 ⁹
Stiffness in lbf/ft	4.1x10 ⁶	6.9x10 ⁶	2.1x10 ⁷	4.8x10 ⁷	5.8x10 ⁷	1.0x10 ⁸	1.4x10 ⁸	2.4x10 ⁸
Material	Aluminum		Stainless steel					

PERFORMANCE SPECIFICATIONS (typical values at temperature 23±3°C)

PARAMETERS	
Operating Temperature Range (OTR)	-20 to 80° C [-4 to 176° F]
Compensated Temperature Range (CTR)	0 to 60° C [32 to 140° F]
Thermal Zero Shift in CTR	<0.5% F.S. /50° C [1/100° F]
Thermal Sensitivity Shift in CTR	<1% of reading / 50° C [1/100° F]
Over-Range	
Without Damage	1.5 x F.S.
Without Destruction	3 x F.S.
Accuracy	
Combined Non-Linearity & Hysteresis	±0.25% F.S.

Electrical Characteristics

Model	FN3002	FN3002-A1	FN3002-A2
Supply Voltage	10Vdc	10 à 30Vdc	±15Vdc (±12 to ±18Vdc)
Sensitivity "FSO" ⁴	±2mV/V	±2V ±0.2V	±5V ±0.2V
Zero Offset ⁴	±5% F.S.	2.5V ±0.2V	0V ±0.2V
Input Impedance/Consumption	350 to 700Ω	<50mA	50mA
Output Impedance	350 to 700Ω	1 kΩ ⁵	1 kΩ ⁵
Insulation under 50Vdc	≥100MΩ	≥100MΩ	≥100MΩ

Notes

1. Electrical Termination: Connector output including mate
2. Materials: Body in stainless steel or aluminium alloy depending on F.S ; aluminum cover
3. Protection Index: IP50 (other protection levels on request)
4. Other signal output on request
5. Output impedance < 100Ω on request
6. CE conformance according to EN 61010-1, EN 50081-1, EN 50082-1

DIMENSIONS & WIRING SCHEMATIC (IN METRIC AND IMPERIAL)

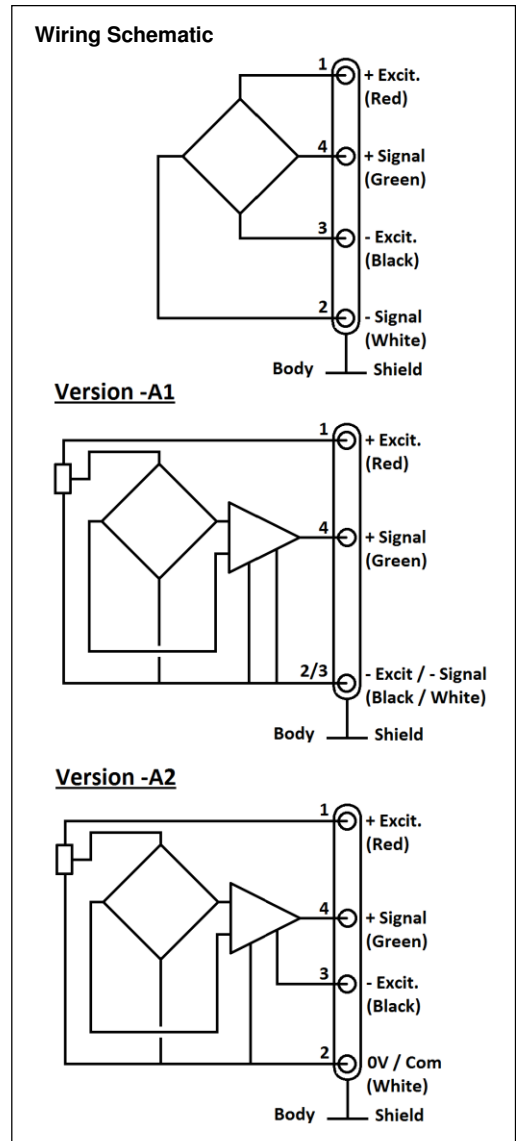
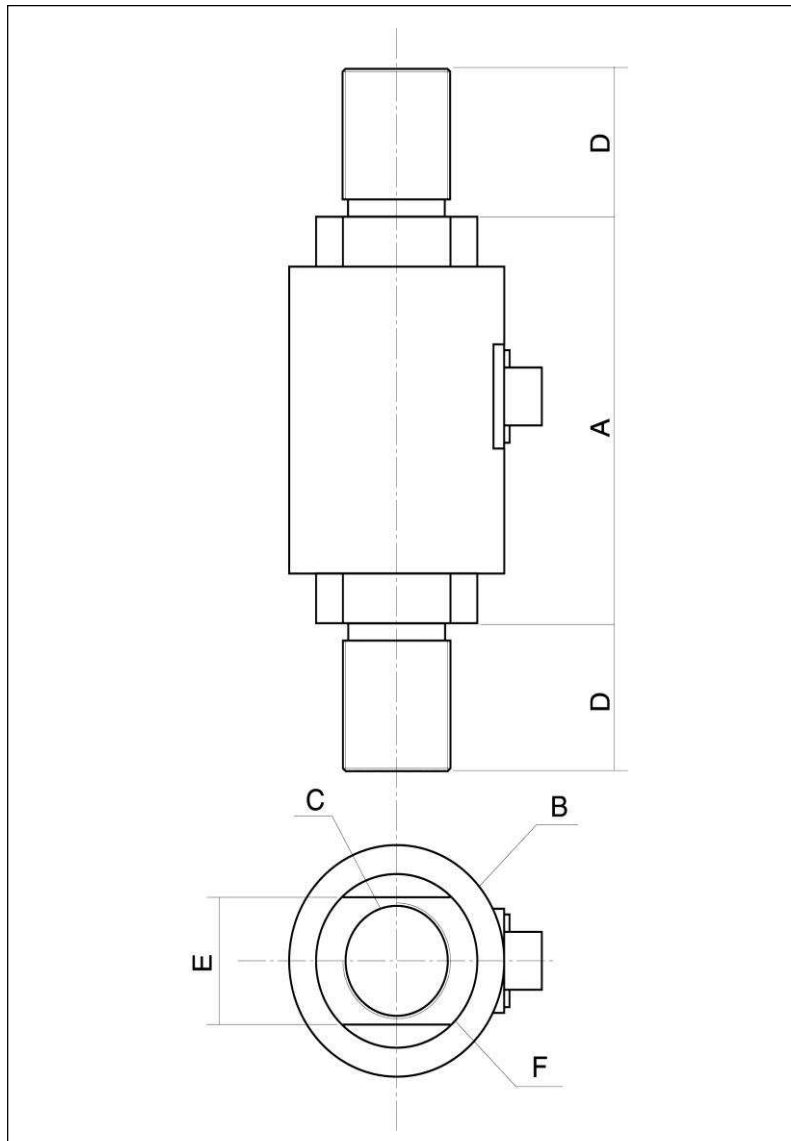

Dimensions in mm [inch]

Ranges in N [in lbf]	10k [2k]	20k [4k]	50k [10k]	100k [20k]	200k [40k]	500k [100k]	1000k [200k]	2000k [400k]
A	70 [2.76]		75 [2.95]	80 [3.15]	85 [3.35]	105 [4.13]	140 [5.51]	160 [6.30]
B	40 [1.57]		50 [1.97]	55 [2.17]	65 [2.56]	85 [3.35]	115 [4.53]	150 [5.91]
C (Thread)	M20x1.5		M22x1.5	M35x1.5	M45x1.5	M64x4	M80x2	M110x2
D	25 [0.98]		25 [0.98]	32 [1.26]	40 [1.57]	70 [2.76]	100 [3.94]	115 [4.53]
E	22 [0.87]		30 [1.18]	36 [1.42]	48 [1.89]	66 [2.60]	85 [3.35]	120 [4.72]
F	30 [1.18]		40 [1.57]	45 [1.77]	55 [2.17]	75 [2.95]	95 [3.74]	130 [5.12]
G	Aluminum		Stainless steel					

FN3002

Load Cell Tension and Compression

OPTIONS

A1 : Amplified Tension output with unipolar power supply
A2 : Amplified Tension output with bipolar power supply
ET1 : CTR -20 to 100° C [-4 to 212° F] OTR = CTR
ET2 : CTR -40 to 120° C [-40 to 248° F] OTR = CTR
ET3 : CTR -40 to 150° C [-40 to 302° F] OTR = CTR (Note : Not available with A1 and A2 options)
P5 : IP65 Protection index
PE : Cable Gland Termination with 2 m [6.5 ft] cable
PE/L00M : Additional cable length with PE option, replace "00" with total length in meters

ORDERING INFO

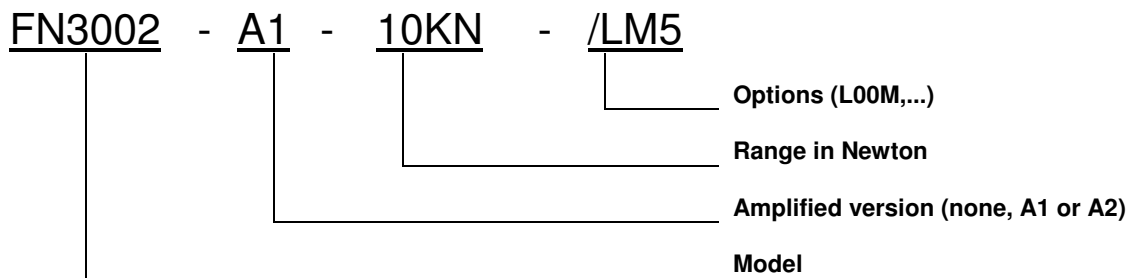

SUPPLIED ACCESSOIRES

EFMX-4M : mating plug Jaeger 530-801-006 with clamp 530-841-006 for standard or ET1 (ranges 10kN to 200kN)
EFMX-4H : mating plug Jaeger 530-804-006 with clamp 530-844-006 for ET2 or ET3 option (ranges 10kN to 200kN)
EFMX-7M : mating plug Jaeger 530-272-006 with clamp 530-371-006 for standard and ET1 (ranges 500kN to 2MN)
EFMX-7H : mating plug Jaeger 530-604-006 with clamp 530-693-006 for ET2 or ET3 option (ranges 500kN to 2MN)

RECOMMENDED ACCESSORIES

NORTH AMERICA	EUROPE	ASIA
Measurement Specialties, Inc., a TE Connectivity Company Vibration Design Center 32 Journey - Suite 150 Aliso Viejo, CA 92656 United States USA Tel: 1-949-716-0877 Fax: 1-949-916-5677 t&m@meas-spec.com	Measurement Specialties (Europe), Ltd., a TE Connectivity Company 26 Rue des Dames 78340 Les Clayes-Sous-Bois, France Tel: +33 (0) 130 79 33 00 Fax: +33 (0) 134 81 03 59 cs.lcsb@meas-spec.com	Measurement Specialties (China), Ltd., a TE Connectivity Company No. 26 Langshan Road Shenzhen High-Tech Park (North) Nanshan District, Shenzhen 518057 China Phone: +86-755-33305088 Fax: +86-755-33305099 pfg.cs.asia@meas-spec.com

TE.com/sensorsolutions

Measurement Specialties, Inc., a TE Connectivity company.

Measurement Specialties, TE Connectivity, TE Connectivity (logo) and EVERY CONNECTION COUNTS are trademarks. All other logos, products and/or company names referred to herein might be trademarks of their respective owners.

The information given herein, including drawings, illustrations and schematics which are intended for illustration purposes only, is believed to be reliable. However, TE Connectivity makes no warranties as to its accuracy or completeness and disclaims any liability in connection with its use. TE Connectivity's obligations shall only be as set forth in TE Connectivity's Standard Terms and Conditions of Sale for this product and in no case will TE Connectivity be liable for any incidental, indirect or consequential damages arising out of the sale, resale, use or misuse of the product. Users of TE Connectivity products should make their own evaluation to determine the suitability of each such product for the specific application.

© 2015 TE Connectivity Ltd. family of companies All Rights Reserved.